

JABEZ

雅比斯國際有限公司
Jabez International Co., Ltd.

402台中市南區三民西路342號

ADD:
No.342, Sanmin W. Rd., South Dist.,
Taichung City 402, Taiwan (R.O.C.)

TEL: 04-23781018
FAX: 04-23780938

Email: jabez.aai@gmail.com
Web: www.jabez.com.tw

JABEZ

雅比斯國際有限公司

Support Arm and Control Panel Systems



JABEZ

超越質感 難以抗拒



目錄頁 Table of Contents

	DST60/105/155/180 控制箱 DST60/105/155/180 Control Cabinet	P3		5575 系列 中型懸臂組件 5575 Series Medium Type Support Arm Units	P45
	DST210/140 控制箱 DST210/140 Control Cabinet	P9		6085 系列 60中重型懸臂組件 6085 Series Support Arm Units	P51
	DST210FD/RD 前/後開門控制箱 DST210FD/RD Front Door/ Rear Door Control Cabinet	P11		70100 系列 70中重型懸臂組件 70100 Series Support Arm Units New!	P55
	DST200/130 控制箱 DST200/130 Control Cabinet	P19		80 系列 重型懸臂組件 80 Series Heavy Support Arm Units	P59
	DST190/120 控制箱 DST190/120 Control Cabinet	P27		DA 系列 鑄鋁接線盒及附件 DA Series Casting Aluminum Terminal Box	P63
	DST150 控制箱 DST150 Control Cabinet	P31		電控箱櫃 Electronic Cabinet	P71
	控制箱支架 Control Cabinet Stand	P35		通風過濾網組系列 Fan Filter Series	P77
	KL 3550 系列 微型懸臂組件 KL 3550 Series Minisize Support Arm Units	P38		數控邊角成型機 CNC Corner Forming Machine	P82
	4460 系列 輕型懸臂組件 4460 Series Lightweight Support Arm Units	P41			

DST60/105/155/180系列控制箱由高品質陽極氧化鋁型材和鋁壓鑄角部
件組裝而成。外觀採用窄邊框設計，現代感十足。表面陽極氧化的鋁型材更
易於擦拭，始終保持箱體光亮如新。前面板可以前裝或後裝，展現不同的視
覺效果。

控制箱廣泛應用在數控機床，裝配線及專用設備上各式人機界面操控和
附件的安裝，配合懸臂或支撐系統，完全能符合實際操作的要求。

箱體尺寸均按用戶需求定製。

DST60/105/155/180 series of control cabinet are assembly of
superior anodized aluminum section bar and die-casting aluminum corner
pieces. Narrow-Bezeled appearance meets modern aesthetic. Surface of
anodized aluminum is more easily to wipe; hence the cabinet could stay
brightly new all the time. Front panels could be optionally installed
outwards or inwards to achieve different visual effects.

Control cabinets are widely applied to CNC machine tools, assembly
lines, and setup of all kinds of HMIs (human machine interfaces) and
accessories for specialized facilities. Together with support arm and stand
system, the cabinets could meet requirements for all operation.

Sizes of cabinets all customized.



基本性能及參數

有效安裝深度（前面板後裝）：

- DST60：60mm（前面板前裝：66mm）
- DST105：105mm（前面板前裝：111mm）
- DST155：152.5mm（前面板前裝：158.5mm）
- DST180：176.5mm（前面板前裝：182.5mm）

定製最大尺寸：

前面板寬度<700mm; 前面板高度<800mm

防護等級：

後開門：IP54; 螺釘固定後面板：IP65

材料：

鋁型材和把手：鋁合金6063
角部件和把手固定件：壓鑄鋁合金102

顏色：

鋁型材和把手：陽極氧化鋁本色
角部件和把手：岩石灰，近似RAL7012
後門（後面板）：3mm鋁板
表面噴塗，銀灰色

Fundamental characteristics and parameter：

Effective installation depth (Front panel installed inwards)：

- DST60：60mm（Front panel installed outwards: 66mm）
- DST105：105mm（Front panel installed outwards: 111mm）
- DST155：152.5mm（Front panel installed outwards: 158.5mm）
- DST180：176.5mm（Front panel installed outwards: 182.5mm）

Maximum size of customization：

Width of front panel <700mm; Height of front panel <800mm

Protection rating：

Rear opening：IP54;
Rating panel fixed by screws：IP65

Material：

Aluminum section bar and handle: 6063 aluminum alloy
Corner piece and handle fixture: 102 die-cast aluminum alloy

Color：

Aluminum section bar and handle: Anodized aluminum color
Corner piece and handle: Rock gray akin to RAL7012
Rear panel: 3mm aluminum sheet
Surface coating, silver gray

箱體尺寸示意圖 Schematic of cabinet's size：

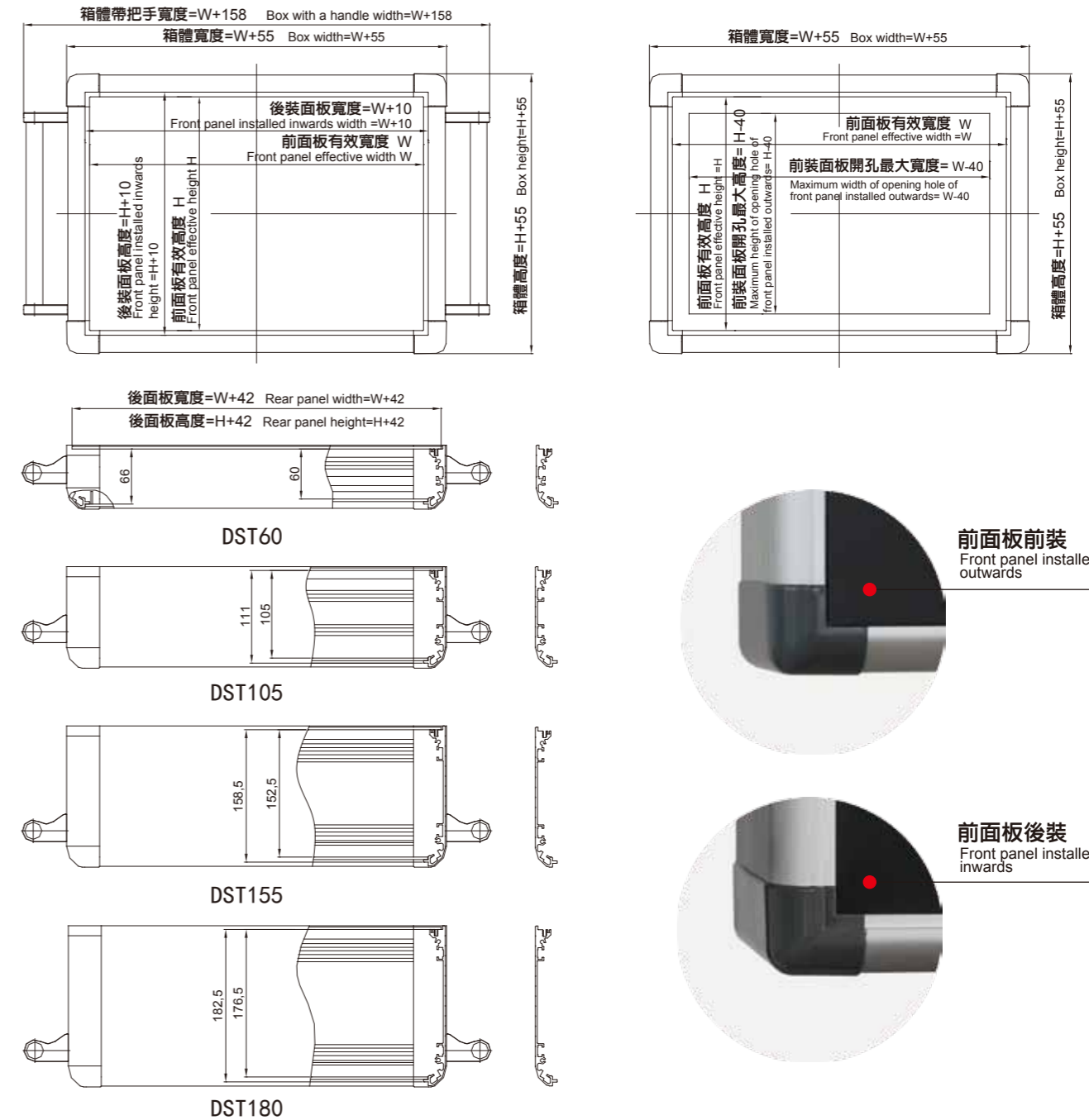

控制箱訂貨號說明 Description of control cabinet order No.：

1. 單體控制箱 Single-box control cabinet



2. 雙體控制箱 Dual-box control cabinet

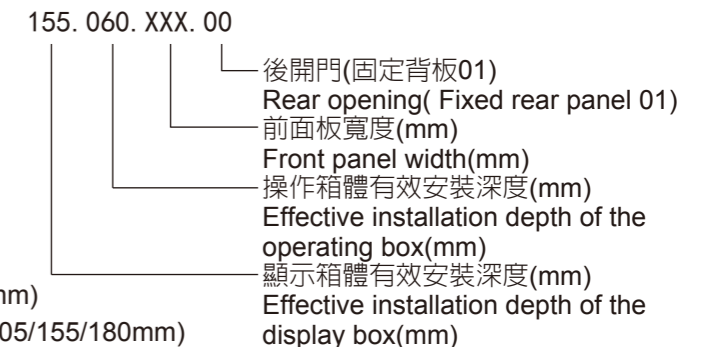

DST60 系列 控制箱
DST60 Series of Control Cabinet

DST60控制箱+ DA901接線盒+ 4460懸臂系統
DST60 control cabinet + DA901 terminal box+ 4460 support arm system

DST60超薄型控制箱體，有效安裝深度僅60mm，需配裝DA901接線盒以及4460箱座來實現吊掛或支撐，並可根據高低使箱體前傾或後仰，提高操作舒適度，符合人體工學。

DST60 ultrathin control cabinets, with effective installation depth 60mm, are assembled with DA901 terminal box and 4460 support arm system, allowing the cabinets lean forward or backward according to the height to improve comfortability in using.



顯示器+ DA901接線盒+ 4460懸臂系統

1. 顯示器背部安裝孔距：75x75mm 和 100x100mm。
2. 可吊掛或支撐。

可選配的4460箱座訂貨號

- 垂直箱座（詳見第41頁）
- 8度傾斜箱座（詳見第44頁）

Display device+ DA901 terminal box+ 4460 support arm system

1. Rear installation pitch for display device: 75x75mm / 100x100mm
2. Hung/ supported

Optional 4460 box base order No.

- Vertical box base : 440.6.090.00 (see p.41)
- 8-degree-tilt box base : 440.6.080.00 (see p.44)

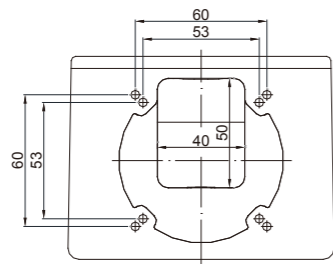
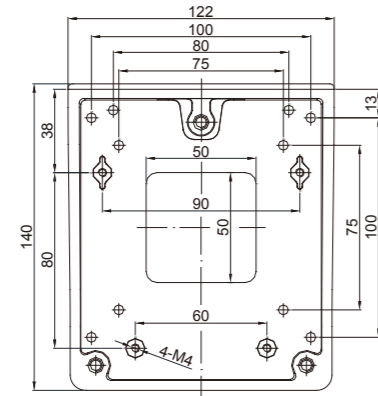
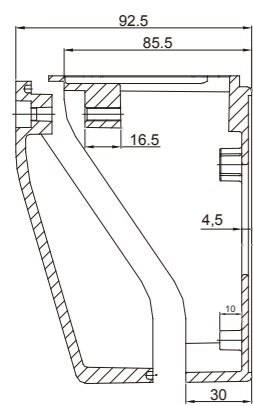

DA901接線盒安裝尺寸
Installation size of DA901 terminal box



DST60/105/155/180系列 控制箱
DST60/105/155/180 Series of Control Cabinet



DST155-60雙體
DST155-60 dual-box



調節角度並鎖緊
Adjusting angles and tightening



穿線管
Threading tube

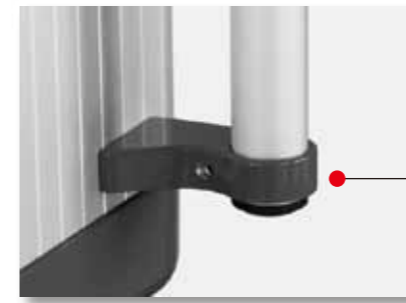

兩側把手
Handles on both sides



前拉把手
Pulling-forward handle

DST105單體
DST105 Single-box



DST60/105/155可配接的懸臂系統及附件
DST60/105/155 Optional support arm system and accessories

DST60	DA901 接線盒+4460系列懸臂系統 DA901 Terminal box+ 4460 Series of Control Cabinet
	DA901 接線盒+液晶顯示螢幕 DA901 Terminal box+ LCD
DST105	4460系列懸臂系統 4460 Series of Control Cabinet
DST155	4460、5575、70100、80系列懸臂系統 4460、5575、70100、80 Series of Control Cabinet
DST180	4460、5575、70100、80系列懸臂系統 4460、5575、70100、80 Series of Control Cabinet

活動鍵盤托

KBM可收納鍵盤托架，展開時略向下傾斜，便於操作鍵盤收起後與箱體為同一整體，內部空間可收納鍵盤滑鼠等物件。

該鍵盤托適用於DST60/105/155/180控制箱體。

Movable Keyboard Tray

KBM movable keyboard tray makes it easy to use the keyboard by unfolding itself downslope; while folded, it shifts into a whole unity with the box, having enough space for the keyboard, mouse, etc..

This keyboard tray is suitable for DST60 /105/ 155/ 180 series of control cabinets.



鋁合金把手
Aluminum alloy handle



防滑落折邊設計
Anti-slipping folding edge

可收納鍵盤托架安裝尺寸：
 Installation size of movable keyboard tray :

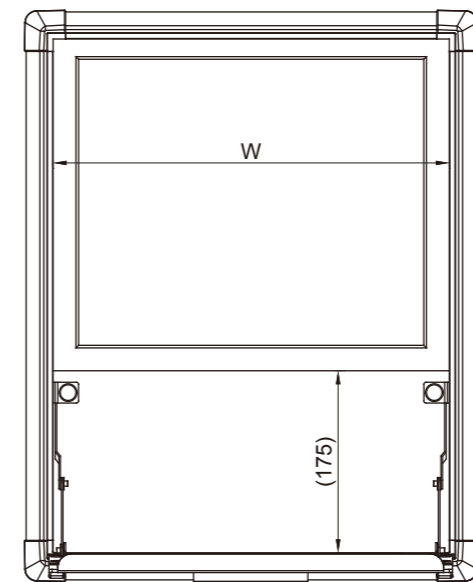
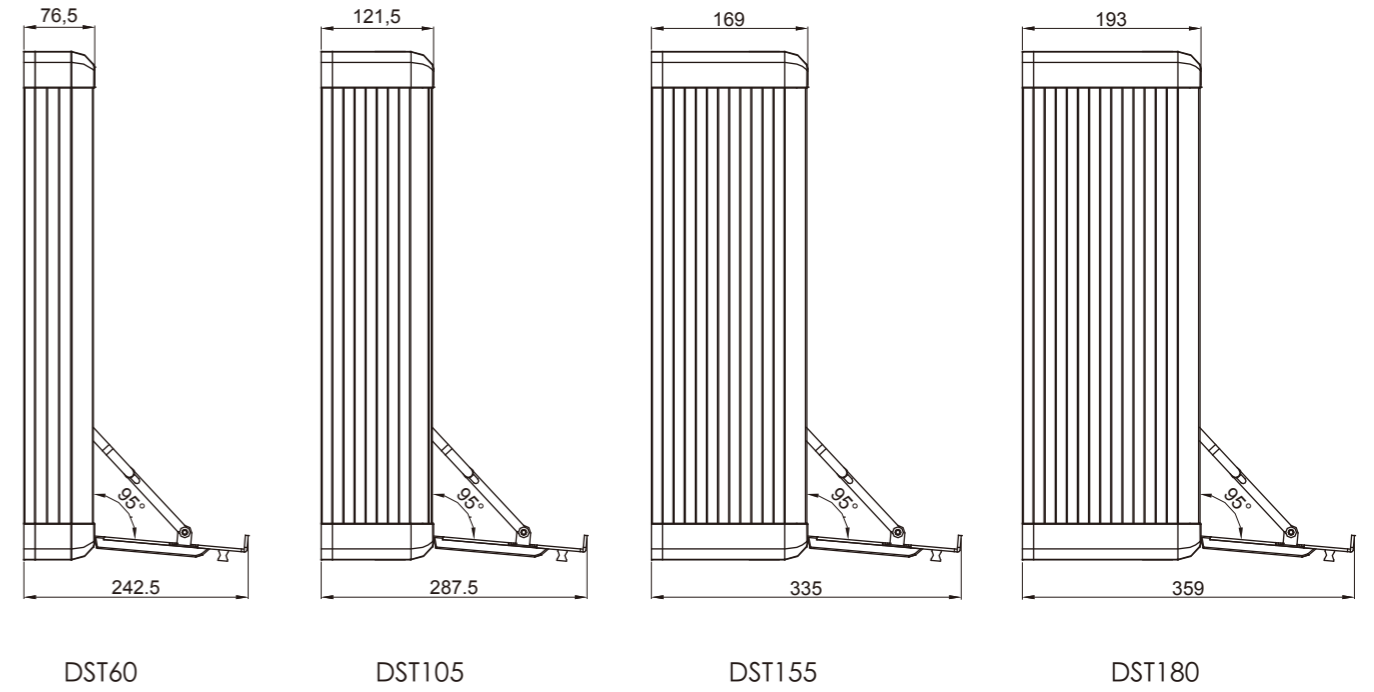

箱體寬度=顯示器寬度W+55
 Body width= Display width+55

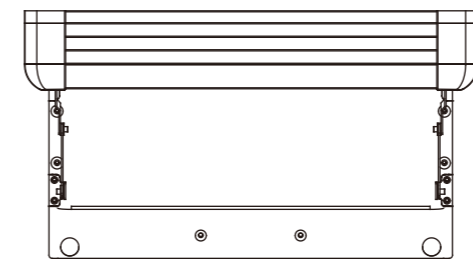

顯示器貼邊安裝
 Installation and padding of the display



拉桿、門吸
 Pull rod、magnetic catch





DST210/DST140系列控制箱由高品質陽極氧化鋁型材和鋁壓鑄角部件組裝而成。簡潔外觀設計，結構穩固。表面陽極氧化的鋁型材更易於擦拭，始終保持箱體光亮如新。

控制箱廣泛應用在數控機床，裝配線及專用設備上各類人機界面和附件的安裝，配合懸臂或支撐系統，完全能符合實際操作的要求。

箱體尺寸均按用戶需求定製。

DST210/DST140 series of control cabinets are assembly of superior anodized aluminum section bar and die-casting aluminum corner pieces. They possess concise appearance and firm structure. Surface of anodized aluminum is more easily to wipe; hence the cabinet could stay brightly new all the time.

Control Cabinets are widely applied to CNC machine tools, assembly lines, and setup of all kinds of HMIs (human machine interfaces) and accessories for specialized facilities. Together with support arm and stand system, the cabinets could meet requirements for all operation.

Sizes of cabinets all customized



基本性能及參數：

有效安裝深度：

DST210：210mm; DST140：140mm

定製最大尺寸：

前面板寬度<700mm; 前面板高度<800mm

防護等級：

後開門：IP54; 螺釘固定後面板：IP65

材料：

鋁型材和把手：鋁合金6063

角部件：壓鑄鋁合金102

把手固定件：PA66

顏色：

鋁型材和把手：陽極氧化鋁本色

角部件：岩石灰，近似RAL7012

後門（後面板）：3mm鋁板

表面噴塗，銀灰色

把手固定件：銀灰色

Fundamental characteristics and parameter:

Effective installation depth:

DST210: 210mm; DST140: 140mm

Maximum size of customization:

Width of front panel <700mm; Height of front panel <800mm

Protection rating:

Rear opening: IP54; Rear panel fixed by screws: IP65

Material:

Aluminum section bar and handle: 6063 aluminum alloy

Corner piece: 102 die-cast aluminum alloy

Handle fixture: PA66

Color:

Aluminum section bar and handle: Anodized aluminum color

Corner piece: Rock gray akin to RAL7012

Rear panel: 3mm aluminum sheet

Surface coating, silver gray

Handle fixture: silver gray



箱體尺寸示意圖 Schematic of cabinet size:

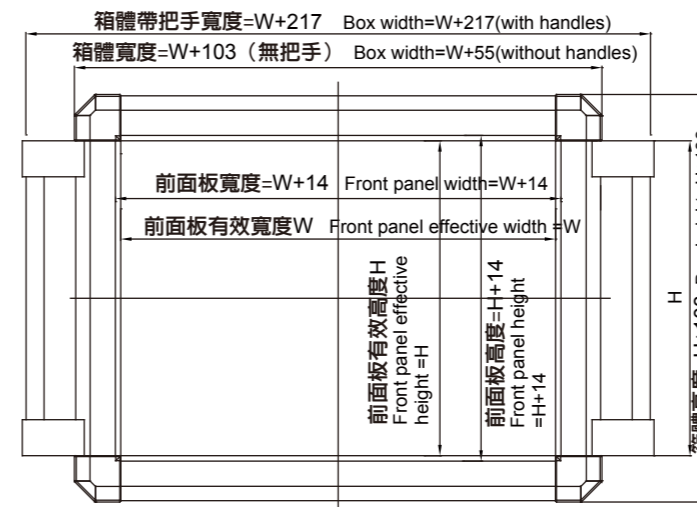

DST210 箱體尺寸 (兩側把手)
DST210 box size (handles on both sides)

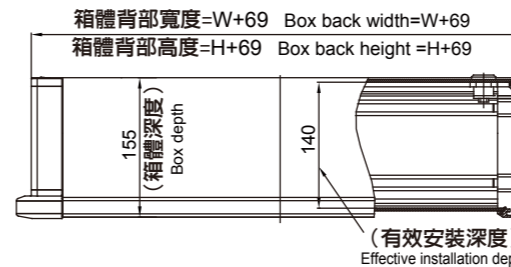
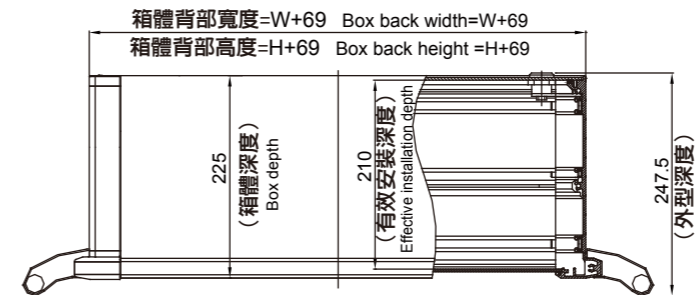

包腳凸邊設計
Convex angle wrapping

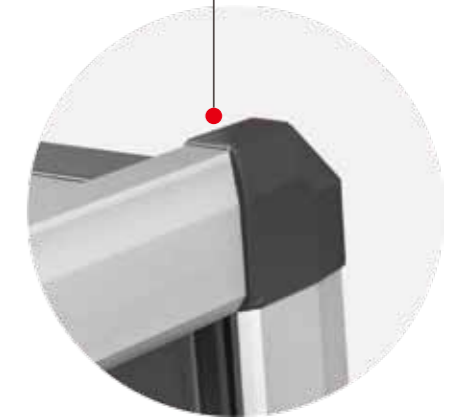

後側整體蓋板
Overall cover plate in rear side

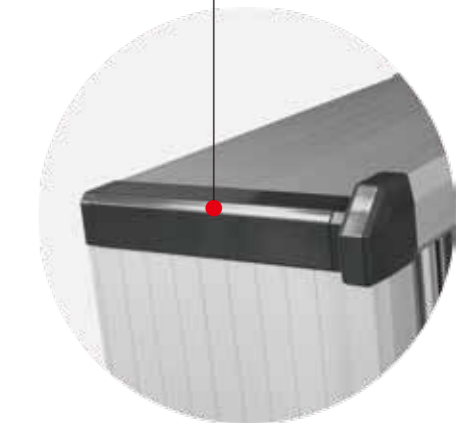

控制箱訂貨號說明 Description of control cabinet order No.:

1. 單體控制箱 Single-box control cabinet

210. XXX. XXX. 00

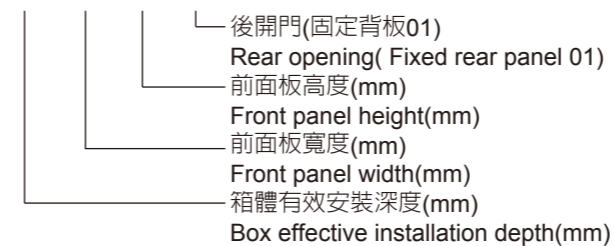

2. 雙體控制箱 Dual-box control cabinet

210. 140. XXX. 00

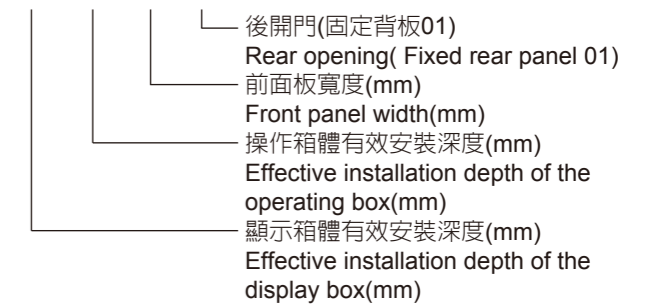

3. 舉例:

- (1) 單體：前面板寬x高為496x478mm。箱體深度為210mm，後開門。 訂貨號：210.496.478.00
(2) 雙體：前面板寬度為496mm。顯示箱體深度210，操作箱體深度140。 訂貨號：210.140.496.00

3. Examples

- (1) Single-box: The widthxheight of the front panel is 496x478mm. The box depth is 210mm. The box is rear-opening. Order NO.:210.496.478.00
(2) Dual-box: The front panel width is 496mm. The display box depth is 210 and the operating box 140. Order NO.:210.140.496.00

DST210FD/290RD 前/後開門控制箱
DST210FD/290RD Front Door / Rear Door Control Cabinet

DST210FD前開門和DST290RD後開門控制箱體是在DST210的基礎上增加了前後開門的功能，通過多款型材的組合可實現最大深度372mm的箱體，滿足不同內部安裝空間的要求。
箱體尺寸均按用戶需求定製。



基本性能及參數：

DST210FD 有效安裝深度：201.5mm

DST290RD 有效安裝深度：290mm

定製最大尺寸：

前面板寬度<700mm;

前面板高度<800mm

防護等級：

後開門：IP54;

螺釘固定後面板：IP65

材料：

鋁型材和把手：鋁合金6063

角部件：壓鑄鋁合金102

把手固定件：PA66

顏色：(同DST210/140系列)

Fundamental characteristics and parameter:

DST210FD effective installation depth: 201.5mm

DST290RD effective installation depth: 290mm

Maximum size of customization:

Width of front panel <700mm;

Height of front panel <800mm

Protection rating:

Rear opening: IP54;

Rear panel fixed by screws: IP65

Material:

Aluminum section bar and handle: 6063 aluminum alloy

Corner piece: 102 die-cast aluminum alloy

Handle fixture: PA66



控制箱訂貨號說明

Description of control cabinet order No.:

210FD. XXX. XXX. 01

- 固定背板(後開門00)
Fixed rear panel (Rear opening 00)
- 前面板高度(mm)
Front panel height(mm)
- 前面板寬度(mm)
Front panel width(mm)
- 箱體有效安裝深度(mm)
Box effective installation depth(mm)

290RD. XXX. XXX. 01

- 固定背板
Fixed rear panel
- 前面板高度(mm)
Front panel height(mm)
- 前面板寬度(mm)
Front panel width(mm)
- 箱體有效安裝深度(mm)
Box effective installation depth(mm)

舉例：

前面板寬 x 高：496 x 478mm。

箱體深度為200mm，固定背板。

訂貨號：210FD.496.478.01

Examples:

The width x height of the front panel is 496 x 478mm.

The box depth is 200mm, with fixed rear panel.

Order NO.:210FD.496.478.01

DST210FD/290RD 前/後開門控制箱
DST210FD/290RD Front Door / Rear Door Control Cabinet

箱體尺寸示意圖：
Schematic of cabinet size：

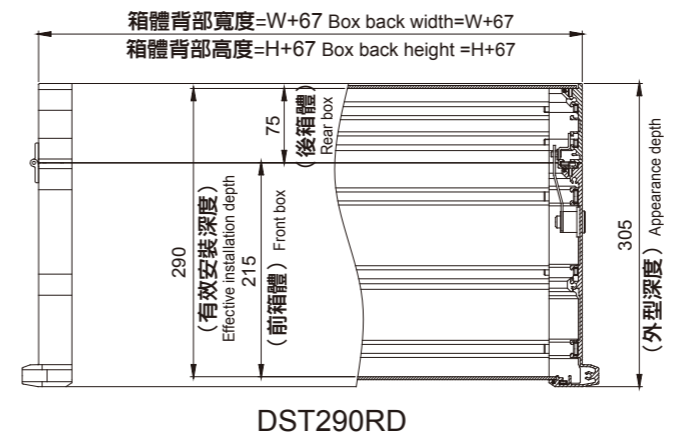
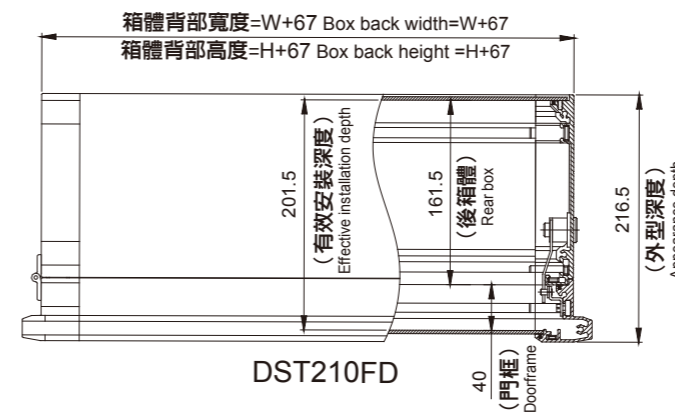
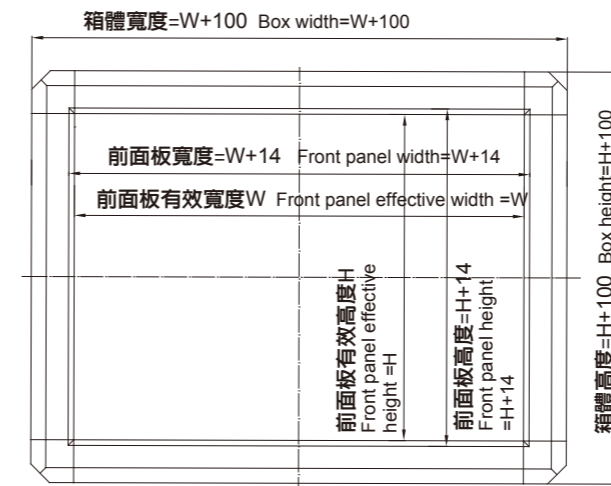

其他型材組合及有效深度
Other section bar assembly and effective installation depth

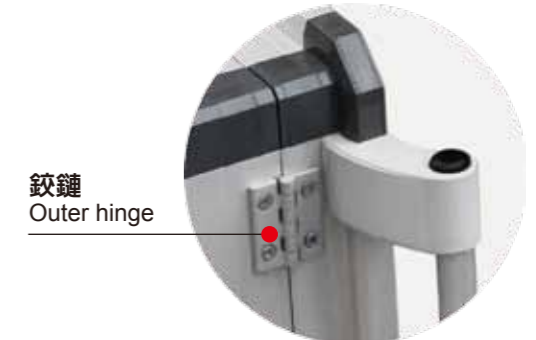
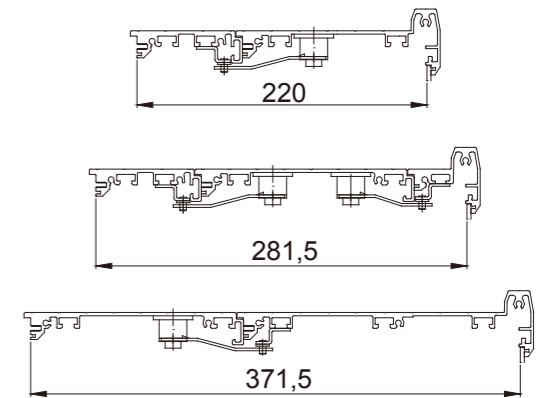

鉸鏈
Outer hinge

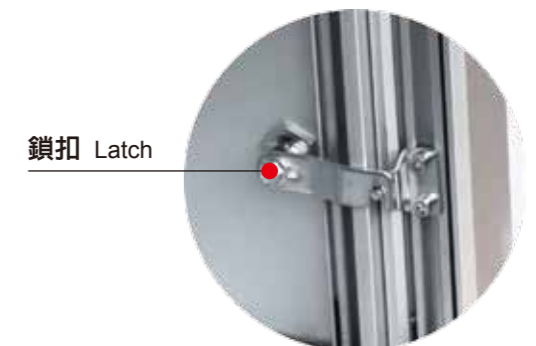

鎖扣
Latch





陽極氧化鋁型材
Anodized aluminum section bar



後開門與箱體的電氣連接
Electrical connection between rear door and box



前面板PVC貼膜、絲網印刷
PVC film and silk-screen printing of the front panel



抽屜 訂貨號：210.000.937.00
前框高度90mm，寬度定製
Drawer Order NO. 210.000.937.00
Front frame height 90mm; width customized



風扇(24VDC) 訂貨號：210.000.931.00
濾網 訂貨號：210.000.932.00
Fan(24VDC) Order NO. 210.000.931.00
Filter Order NO. 210.000.932.00



角部加強件
訂貨號：210.000.936.00
Corner stiffener
Order NO. 210.000.936.00

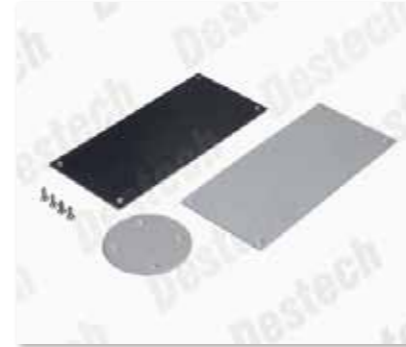

出線鋼板 尺寸：100x220mm
訂貨號：210.000.935.00
Steel outlet cover Size: 100x220mm
Order NO. 210.000.935.00



前面板安裝方式
Installation of the front panel



掛鉤 內徑不大於 Ø15
訂貨號：210.000.934.00
Hook Inner diameter not more than Ø15
Order NO. 210.000.934.00



依客戶需求加工
Box customized



固定螺絲
訂貨號：210.000.933.00
Inner strut(able to be installed with card tracks)
Order NO. 210.000.933.00



DST210箱體頂部加強板
DST210 top reinforcing plate



可設置風扇及濾網幫助散熱
Lateral fan and filter do good to cooling



當前面板寬或高大於600mm時安裝
Installed when the width or height of the front panel is over 600mm.



105° 雙箱體連接管
訂貨號：210.000.938.00
Hard joint (for connection of the operation box)
Order NO. 210.000.938.00

雙箱體連接管內徑尺寸：
Bore size of the hard joint

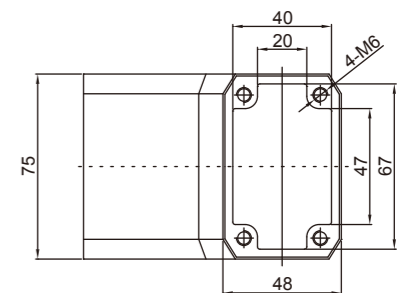



1. DST210配裝SIEMENS系統
2. DST210配裝三菱系統
3. DST210-140配裝NUM系統

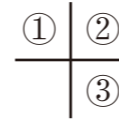
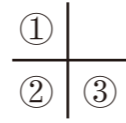

1. DST210配裝FANUC系統
 2. DST210配裝FANUC系統
 3. DST210-140配裝HEIDENHAIN系統
1. DST210 assembled with FANUC system
 2. DST210 assembled with FANUC system
 3. DST210-140 assembled with HEIDENHAIN system





- 1. DST210RD後開門配裝SIEMENS系統
- 2. DST140配裝FANUC系統
- 3. DST140配裝觸碰式螢幕

- 1. DST210RD rear opening assembled with SIEMENS system
- 2. DST140 assembled with FANUC system
- 3. DST140 assembled with mini touch screen

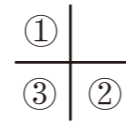

以高品質陽極氧化鋁型材和鋁壓鑄角部件拼接而成，簡潔外觀設計，結構穩固。表面陽極氧化的鋁型材更易於擦拭，始終保持箱體光亮如新。可配合懸臂或支撐系統，完全能符合實際操作的要求，箱體尺寸完全按照需求訂製。



DST 200/ DST130 系列 控制箱
DST 200/ DST130 Series of Control Cabinet

DST200/DST130系列控制箱由高品質鋁型材和鋁壓鑄角部件組裝而成。時尚外觀設計，水平方向型材採用平頂設計，適合外置量儀、動平衡儀等裝置；垂直方向型材表面經過陽極氧化處理並經加寬設計。

控制箱廣泛應用在數控機床，裝配線及專用設備上各類人機界面和附件的安裝，配合懸臂或支撐系統，完全能符合實際操作的要求。

箱體尺寸均按用戶需求定製。

DST 200/ DST130 series of control cabinets are assembly of superior aluminum section bar and die-casting aluminum corner pieces with fashionable-designed appearance. The horizontal section bar is flat-top and suitable for placing measuring instruments and dynamic balance testing instruments; the vertical one anodized and broadened.

The Control Cabinets are widely applied to CNC machine tools, assembly lines, and setup of all kinds of HMIs (human machine interfaces) and accessories for specialized facilities. Together with support arm and stand system, the cabinets could meet all requirements for operation.

Sizes of cabinets all customized

基本性能及參數：

淨安裝深度：

DST200：200mm；DST130：118mm

定製最大尺寸：

前面板寬度<700mm；前面板高度<800mm

防護等級：

後開門：IP54；螺釘固定後面板：IP65

材料：

鋁型材和把手管：鋁合金6063

把手固定件：PA66

角部件：壓鑄鋁合金102

顏色：

水平鋁型材：噴塗，岩石灰 近似RAL7012

垂直鋁型材和把手管：陽極氧化鋁本色

角部件：岩石灰，近似RAL7012

後門（後面板）：噴塗，銀灰色（3mm鋁板）

把手固定件：銀灰色

Fundamental characteristics and parameter:

Net installation depth:

DST200：200mm；DST130：118mm

Maximum size of customization:

Width of front panel <700mm；Height of front panel <800mm

Protection rating:

Rear opening：IP54；Rear panel fixed by screws：IP65

Material:

Aluminum section bar and handle: 6063 aluminum alloy

Handle fixture: PA66

Corner piece: 102 die-cast aluminum alloy

Color:

Horizontal aluminum section bar: spray coating, rock gray akin to RAL7012

Vertical aluminum section bar and handle tube: anodized aluminum color

Corner piece: rock gray akin to RAL7012

Rear panel: spray coating, silver gray (3mm aluminum sheet)

Handle fixture: silver gray



DST 200/ DST130 系列 控制箱
DST 200/ DST130 Series of Control Cabinet

箱體尺寸示意圖 Schematic of cabinet size :

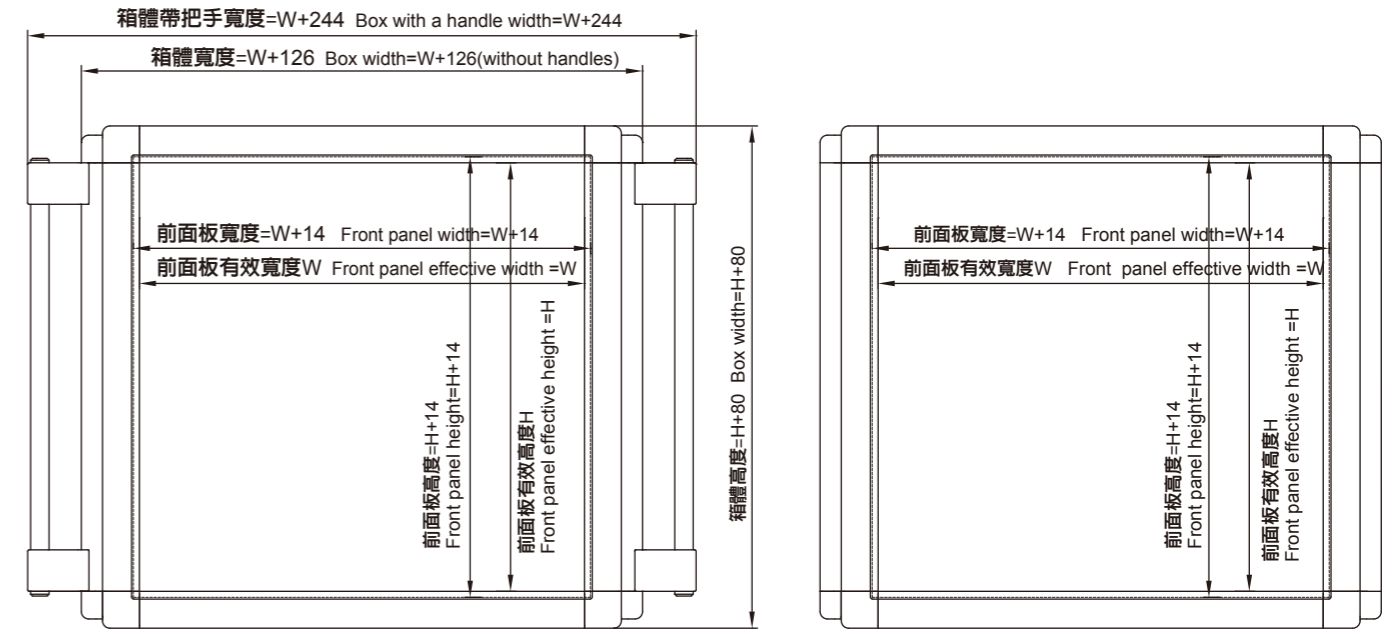

DST200/DST130 箱體尺寸 DST200/DST130 Box size

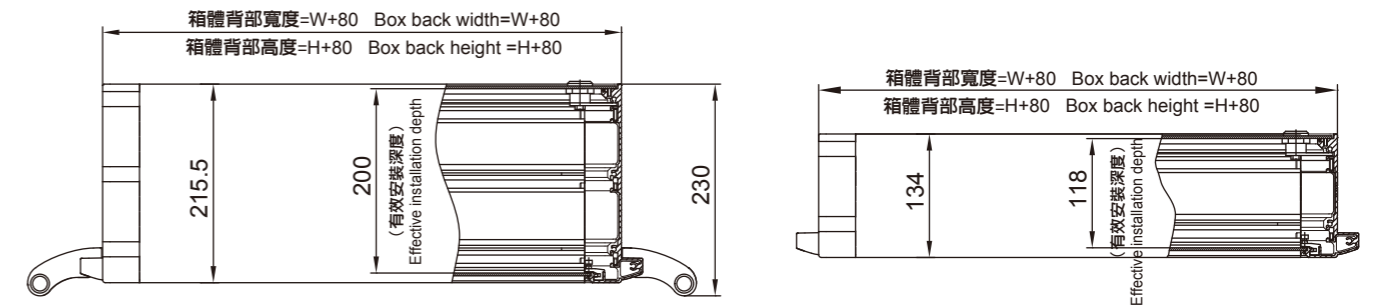

控制箱訂貨號說明 Description of control cabinet order No. :

1. 單體控制箱 Single-box control cabinet

200. XXX. XXX. 00

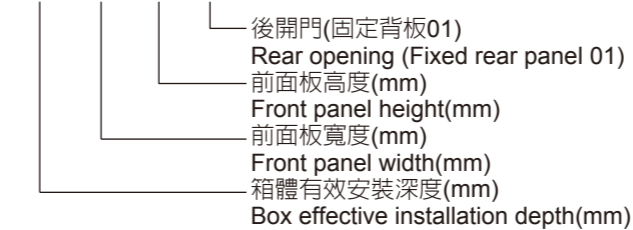

130. XXX. XXX. 00



3. 舉例 :

(1) 單體：前面板寬 x 高為 497 x 479mm。

箱體深度為200mm，後開門。

訂貨號：200.497.479.00

(2) 雙體：前面板寬度為497mm。顯示箱體深度200mm，

操作箱體深度118mm。訂貨號：200.130.497.00

2. 雙體控制箱 Dual-box control cabinet

200. 130. XXX. 00

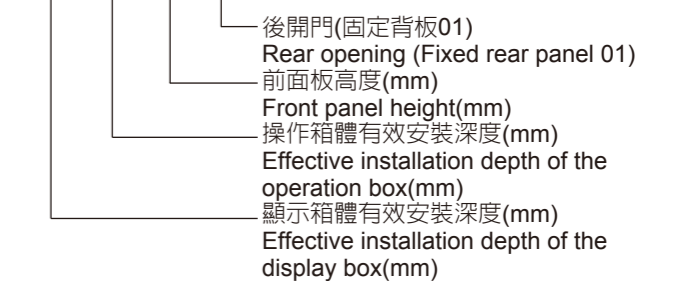

3. Examples :

(1) Single-box: The width x height of the front panel is 497 x 479mm.

The box depth is 200mm. The box is rear-opening.

Order NO.: 200.497.479.00

(2) Dual-box: The front panel width is 497mm.

The display box depth is 200mm and the operation box 118mm.

Order NO.: 200.130.497.00



← 前面板PVC貼膜
 PVC film of front panel

出線鋼板 尺寸：100x220mm
 訂貨號：210.000.935.00
 Outlet steel cover Size：100x220mm
 Order NO.：210.000.935.00

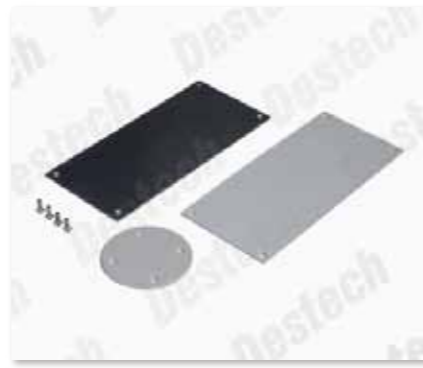

← 掛鈎 內徑不大於Ø15
 訂貨號：210.000.934.00
 Hook Inner diameter not more than Ø15
 Order NO.：210.000.934.00

風扇 訂貨號：210.000.931.00
 濾網 訂貨號：210.000.932.00
 Fan Order NO.：210.000.931.00
 Filter Order NO.：210.000.932.00



← 角部加強件 訂貨號：210.000.936.00
 Corner stiffener
 Order NO.：210.000.936.00

105°硬連接(用於連接琴台箱體)
 訂貨號：210.000.938.00
 105° hard Joint (for combining
 dual-box cabinets)
 Order NO.：210.000.938.00



← 內部支撐件(可安裝卡軌等)
 訂貨號：210.000.933.00
 Inner strut(able to be installed with
 card tracks etc)
 Order NO.：210.000.933.00

抽屜 訂貨號：210.000.937.00
 前框高度90mm，寬度定製
 Drawer Order NO.：210.000.937.00
 Front frame height 90mm;
 Width customized



→ 箱體帶把手的單體應用，左右側的把手為使用者提供更多的方便。

Application of the single box with bilateral handles providing great convenience for users.



← 箱體不帶把手的雙體琴台式應用。上下箱體通過2個105度連接管聯接起來，2個硬連接中間則用於上下箱體的電纜過線通道。

配以懸臂組件，箱體同樣可以懸掛或支撐。

Application of the dual-box cabinets without handles. The upper and lower boxes are combined by two 105° hard joints, as the cable threading of the boxes.

Together with support arm units, the control cabinet could be hung or supported.



適用於較大箱體的防顫底座
 Anti-vibration pedestal for larger-sized box

訂貨號：550.7.080.00 配5575系列（詳見第45頁）
 800.8.080.00 配80系列（詳見第59頁）

Order NO.：Going with the 5575 series (see p.45)
 Going with the 80 series (see p.59)

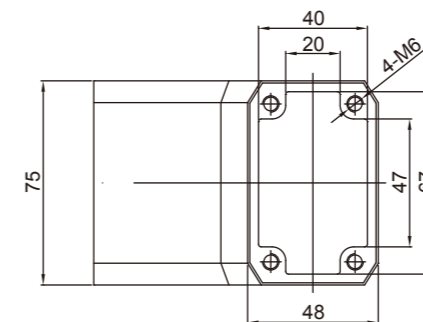

雙箱體連接管內徑尺寸圖
 Bore size of the hard joint

把手結構及安裝示意

Handle structure and installation schematic

1.箱體 2.把手固定件 3.把手管 4.M5x12螺釘 5.M5x8緊定螺釘

1.Box 2.Handle fixture 3.Handle tube
4.M5x12 screw 5.M5x8 set screw

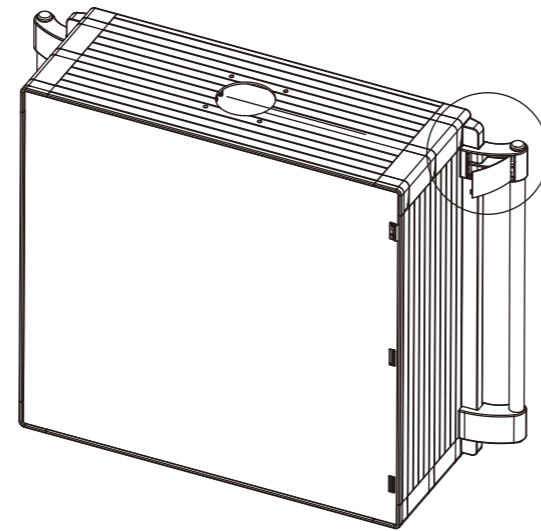
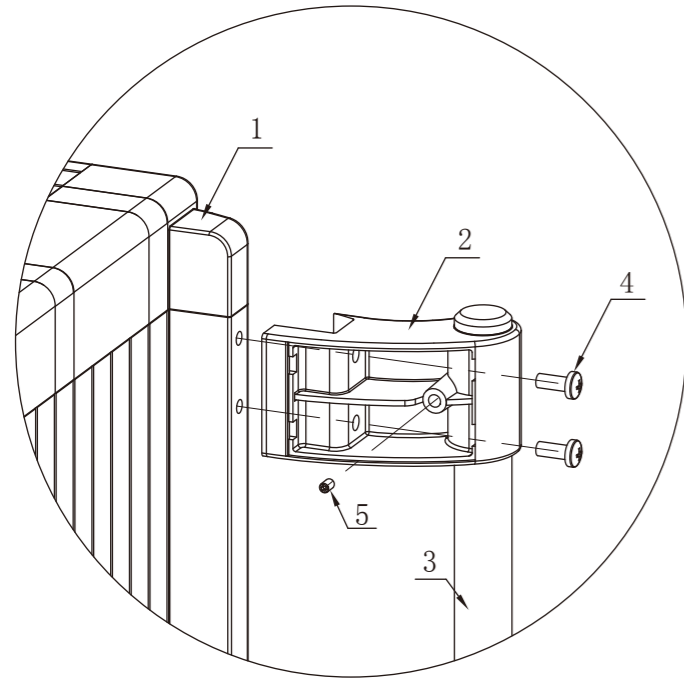

控制箱體

Body part of the control cabinet

出廠時把手固定件和把手管已預裝好，
如發現鬆動，在調整好位置後收緊緊定螺釘。

The handle fixture and the handle tube have
been preinstalled when leaving the factory; if
found loosened, they could be located correctly
and then tightened up.

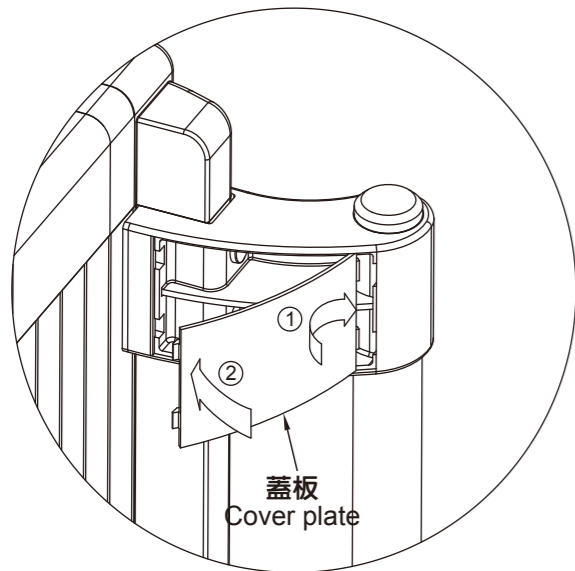

蓋板
Cover plate

把手蓋板安裝步驟：

- 1.把蓋板外端先插入槽內
- 2.順勢轉動蓋板並用力壓平

Steps for installation of handle cover plate:

- 1.Inset the outside of the cover plate into the groove
- 2.Handily rotate the cover plate and flatten it by pressing

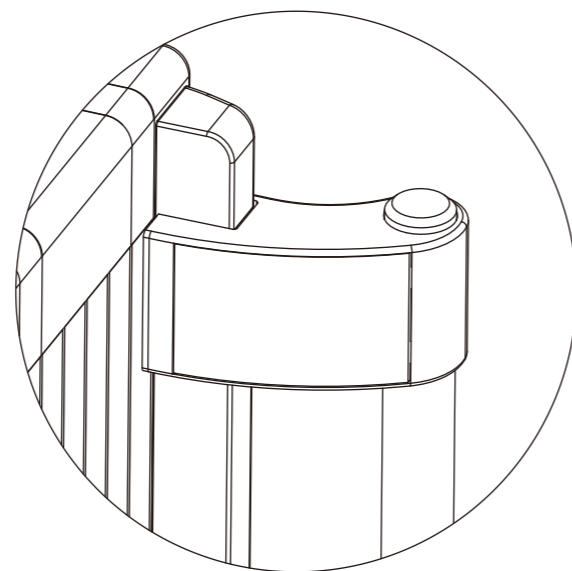

完成
Finished

前面板安裝方式

Installation of the front panel

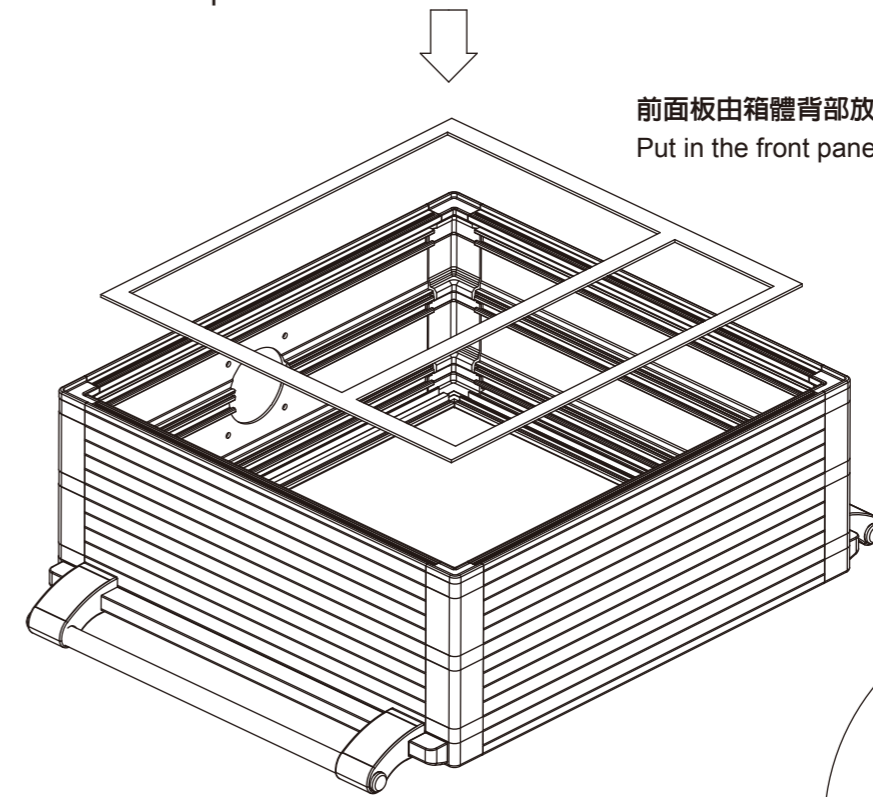

前面板由箱體背部放入

Put in the front panel from the back side of the box

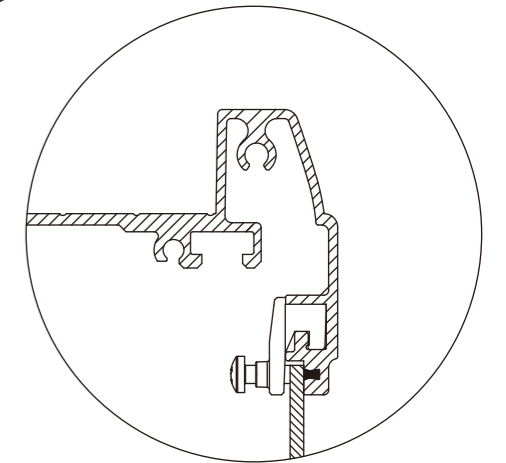

箱體左右側面板安裝

Installation of the front panel on left
and right side

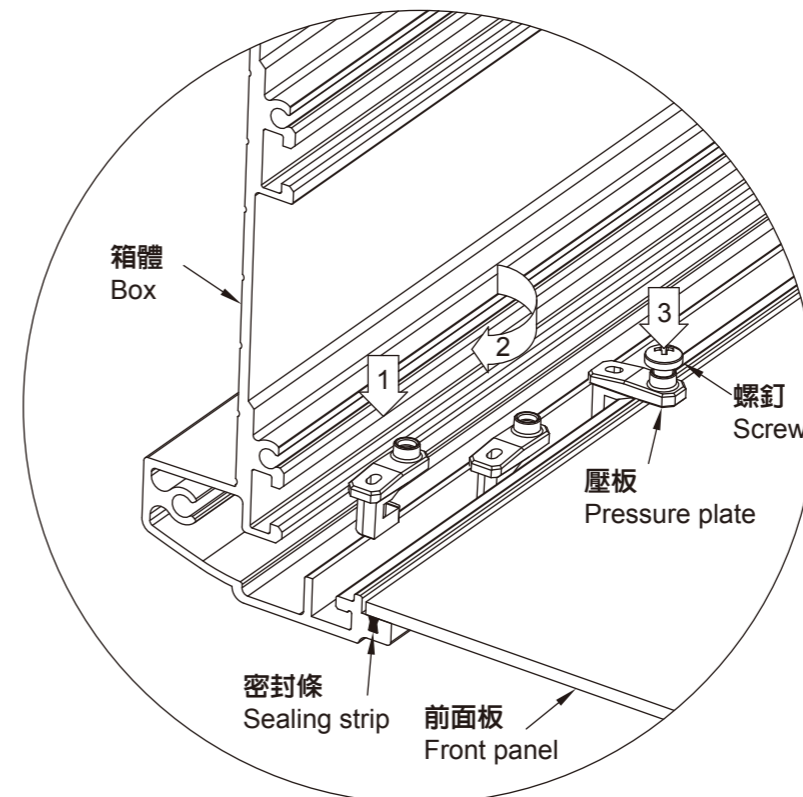

箱體
Box

密封條
Sealing strip

壓板
Pressure plate

螺釘
Screw

前面板
Front panel

前面板四周按以上步驟用若干壓板固定

Follow above steps and fix the front panel with pressure plates

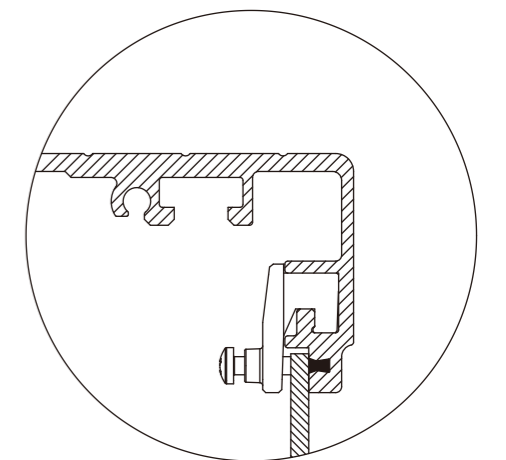

箱體上下側面板安裝

Installation of the front panel on upper
and lower side

端子安裝：
 Terminal installation :

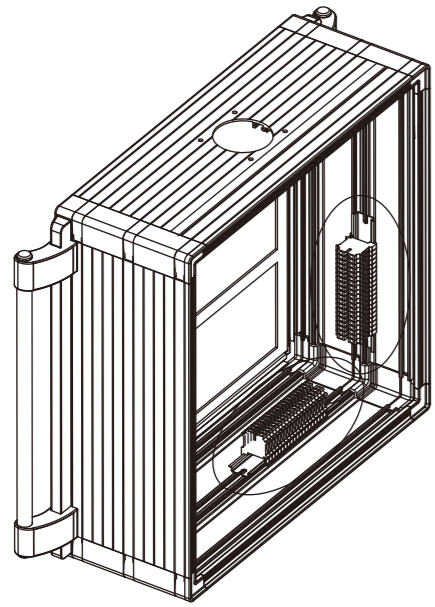

箱體內底部卡槽上安裝
 Installation on the internal bottom groove

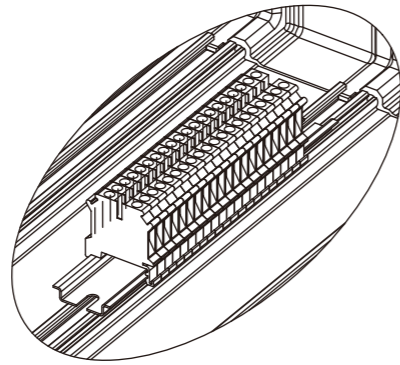

箱體內側面卡槽上安裝
 Installation on the internal lateral groove

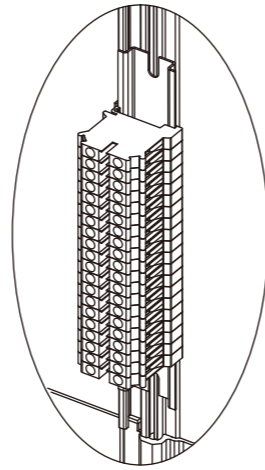

箱體內四周卡槽上均可用所附的螺母來安裝接線端子。
 Attached screws all apply to installation of connecting terminal into surrounding grooves of the box.



硬連接：用於連接琴台上下箱體
 Hard joint: combining the upper and the lower boxes of the control cabinet

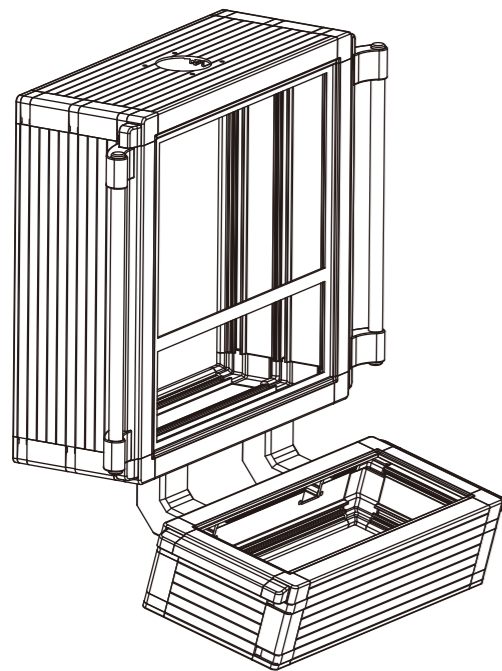

硬連接
 Hard Joint

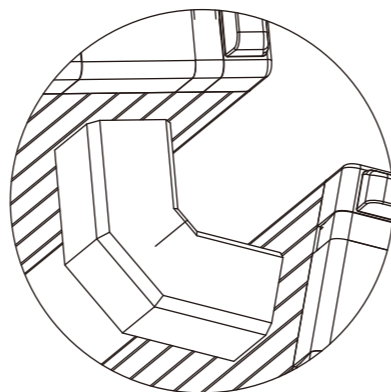
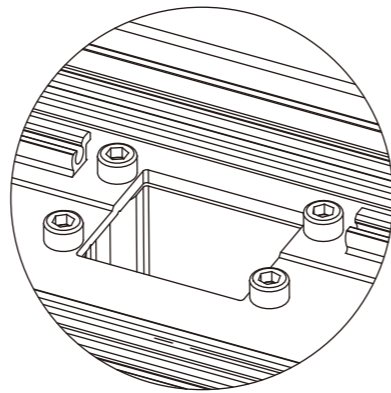
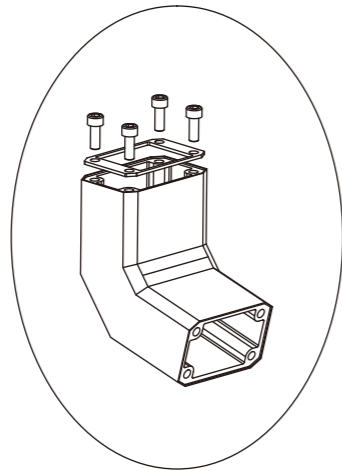

用內六角螺釘和密封墊安裝硬連接，
 兩個硬連接中間均可用於電纜過線。
 Hard joints are installed with hexagon socket screws and gaskets and allow cables through.



DST 190/ DST120 系列 控制箱
DST 190/ DST120 Series of Control Cabinet

該系列控制機箱採用高質量鋁型材製造，廣泛應用於數控機床，生產線及專用設備上數控系統和各類觸摸屏的安裝。可與各種懸臂或支撐系統配合使用，箱體尺寸均按用戶要求定製。

DST 190/ DST120 series of control cabinets are assembly of superior aluminum section bar and widely applied to CNC machine tools, assembly lines, and setup of all kinds of CNC systems and touch panels for specialized facilities. Together with support arm and stand system, the size of cabinets are all customized.



基本性能及參數：

淨安裝深度：

DST190：190mm；DST120：120mm

定製最大尺寸：

前面板寬度<800mm；前面板高度<800mm

防護等級：後開門：IP54；固定背板：IP65

材料和顏色：

箱體：鋁合金6063；噴塗RAL7035（淺灰）

把手：鋁合金或鋼管，噴塗Pantone3145C

前面板：3mm鋁板，噴塗RAL7035（或定製）

後面板（後門）：3mm鋁板，噴塗RAL7035

正面墊圈：工程塑料，RAL9005黑色

側面墊圈：橡膠，RAL9005黑色

螺釘孔蓋：PA6尼龍，RAL7035淺灰

Fundamental characteristics and parameter：

Net installation depth：

DST190：190mm；DST120：120mm

Maximum size of customization：

Width of front panel <800mm；height of front panel <800mm

Protection rating：rear opening：IP54；fixed rear panel：IP65

Material and Color：

Box: 6063 aluminum alloy; spray coating RAL7035 (light grey)

Handle: Aluminum alloy / steel tube, spray coating Pantone3145C

Front Panel: 3mm aluminum sheet, spray coating RAL7035(or customized)

Rear Panel(door): 3mm aluminum sheet, spray coating RAL7035

Front gasket: engineering plastics, RAL9005 black

Side gasket: rubber, RAL9005 black

Hole cover: PA6 nylon, RAL7035 light grey

DST 190/ DST120 系列 控制箱
DST 190/ DST120 Series of Control Cabinet

箱體尺寸示意圖 Schematic of cabinet's size：

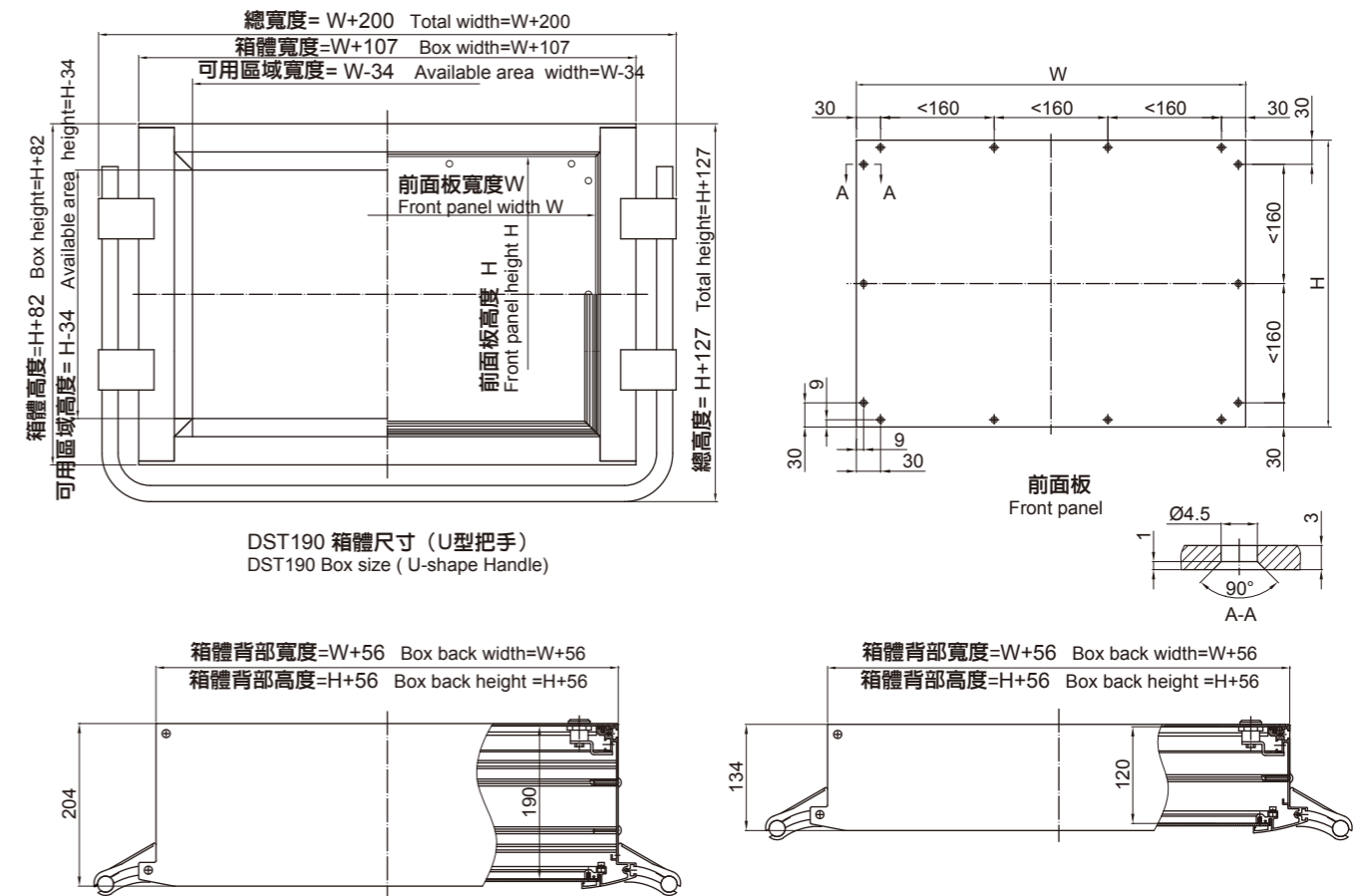

控制箱訂貨號說明 Description of control cabinet order No.：

1. 單體控制箱 Single-box control cabinet

190. XXX. XXX. 00

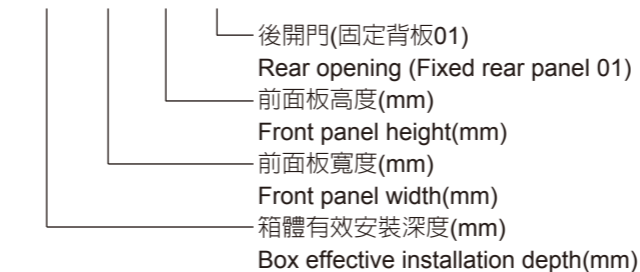

120. XXX. XXX. 00

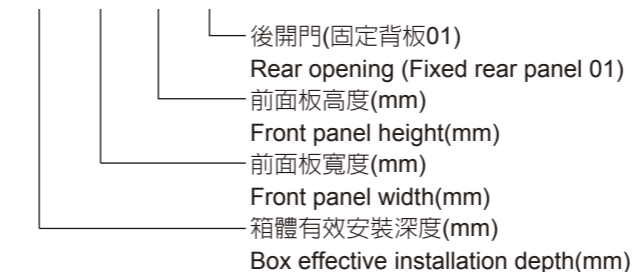

3. 舉例：

- (1) 單體：前面板寬x高為517x499mm。箱體深度為190mm，後開門。訂貨號：190.517.499.00
- (2) 雙體：前面板寬度為517mm。顯示箱體深度190，操作箱體深度120。訂貨號：190.120.517.00

2. 雙體控制箱 Dual-box control cabinet

190. 120. XXX. 00

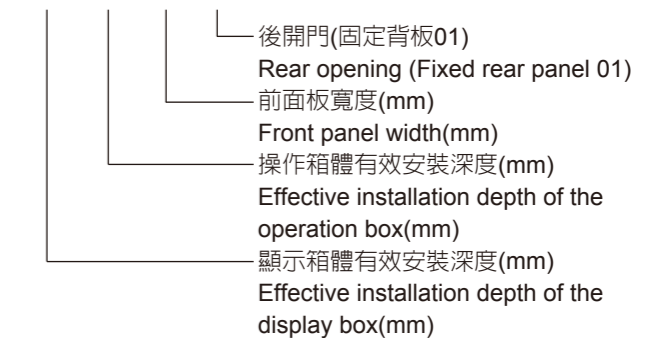

3. Examples：

- (1) Single-box: The widthxheight of the front panel is 517x499mm. The box depth is 190mm. The box is rear-opening. Order NO.: 190.517.499.00
- (2) Dual-box: The front panel width is 517mm. The display box depth is 190 and the operation box depth 120. Order NO.: 190.120.517.00



②	①
③	

1. DST190-120配裝FANUC系統
 2. DST190配裝FANUC系統
 3. DST190-120配SIEMENS系統
(配BERNSTEIN可移動托架)
1. DST190-120 assembled with FANUC system
 2. DST190 assembled with FANUC system
 3. DST190-120 assembled with SIEMENS system
(Matching BERNSTEIN movable stand)



箱體內安裝接線端子
 Installation of connecting terminal into the box.



箱體內橫隔板
 Partition inside the box

硬連接內孔尺寸
 Bore size of the hard joint

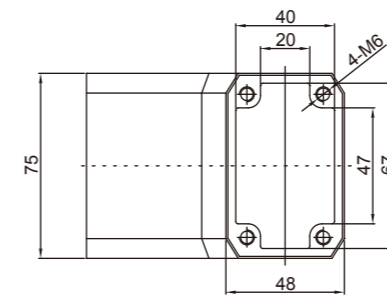

關於控制箱安裝附件：
 由於控制箱內部器件安裝的多樣化，造成某些安裝需要特殊的定製附件，我們將根據客戶的設計要求製作，或者按客戶提出的設想來設計並完成方案。

About Installation Accessories of the Control Cabinet:
 For the variety of the inner parts of the cabinet, some special customized parts would be needed. We could manufacture as customers' design, and design as customers' images to work out their projects.

DST150 系列 控制箱 DST150 Series of Control Cabinet

該系列控制機箱採用高質量鋁型材製造，外表噴塑。廣泛應用於數控機床，生產線及專用設備上數控系統和各類觸摸屏的安裝。
箱體通過轉軸部件可直接安裝於床身實現左側單軸旋轉或者右側單軸旋轉，也可製成標準對稱箱體與各種懸臂或支撐系統配合使用，箱體尺寸（寬X高）可按要求定製。

DST150 series of control cabinet are assembly of superior aluminum section bar with plastic-spray appearance and widely applied to CNC machine tools, assembly lines, and setup of all kinds of CNC systems and touch panels for specialized facilities.
The control cabinet could be installed onto the machine by the rotation hinge to carry out left-side and right-side single axis rotation. It could as well be made standard symmetry cabinet matching kinds of support arm and stand system; the sizes(width X height) of cabinets are all customized.

基本性能及參數：
淨安裝深度：131mm
定製最大尺寸：
前面板寬度<800mm; 前面板高度<800mm
防護等級：IP65
材料和顏色：
箱體：鋁合金6063：噴塗RAL7035（淺灰）
前面板：3mm鋁板，噴塗RAL7035（或定製）
後面板：3mm鋁板，噴塗RAL7035
螺釘孔蓋：PA6尼龍，RAL7035淺灰
箱體背部可穿線纜最大直徑：$\phi 20\text{mm}$
該系列箱體不另配把手。

Fundamental characteristics and parameter：
Net installation depth：131mm
Maximum size of customization：
Width of front panel <math><800\text{mm}</math>; height of front panel <math><800\text{mm}</math>
Protection rating：IP65
Material and Color：
Box: 6063 aluminum alloy; spray coating RAL7035 (light grey)
Front Panel: 3mm aluminum sheet, spray coating RAL7035 (or customized)
Rear panel: 3mm aluminum sheet, spray coating RAL7035
Hole cover: PA6 nylon, RAL7035 light gray
The maximum threaded diameter in the rear box: $\phi 20\text{mm}$
The series are NOT equipped with handles.

箱體轉軸結構：
Rotation hinge structure of the box:



箱體平行於安裝面。
Box parallel to the fitting surface



箱體旋轉90度位置。
Box vertical to the fitting surface



位於箱體內部的轉軸結構。
Rotation hinge structure within the box



DST150 系列 控制箱 DST150 Series of Control Cabinet

單軸轉箱體尺寸 Size of single rotation hinge box

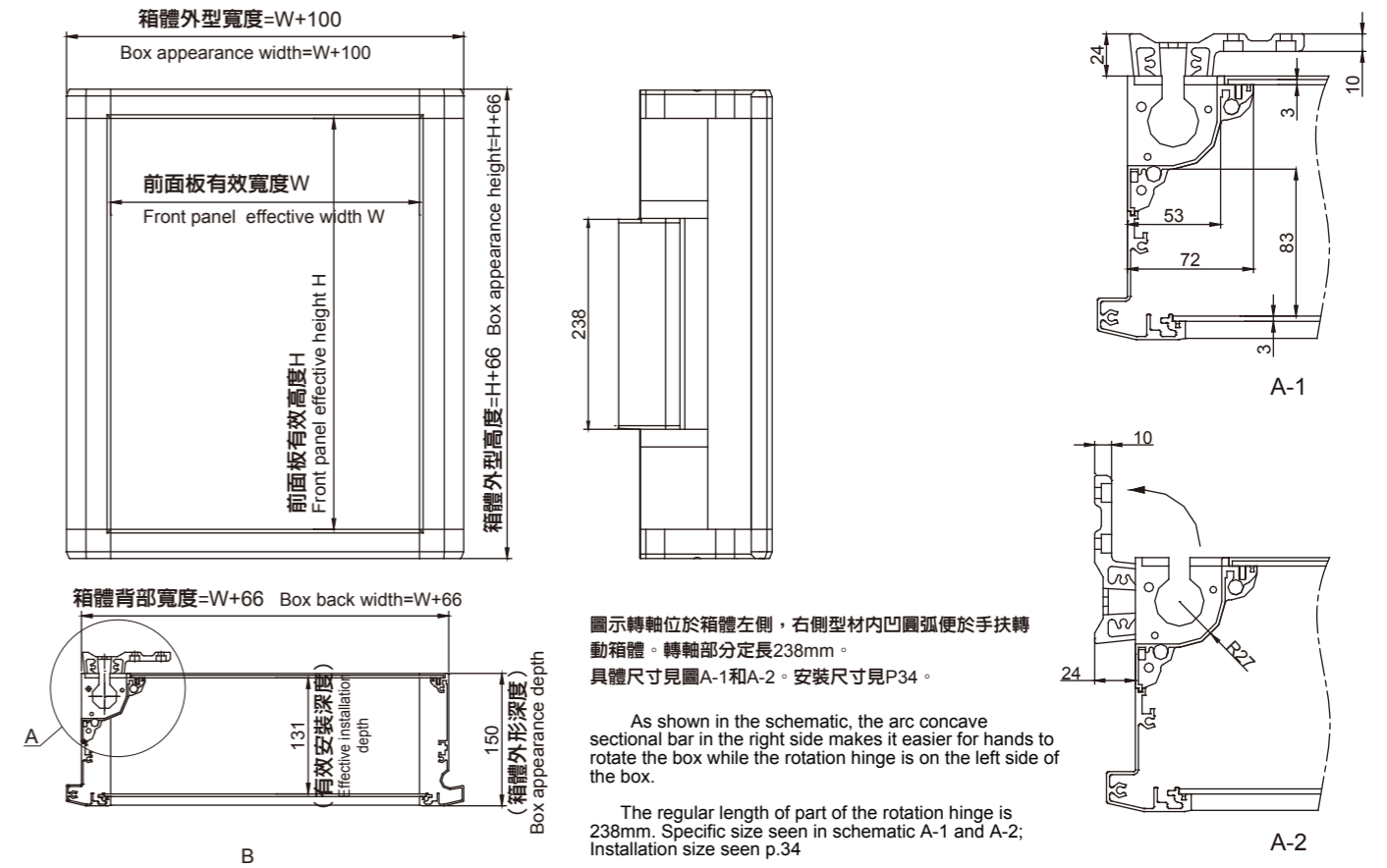

標準對稱箱體尺寸 Standard symmetrical box size

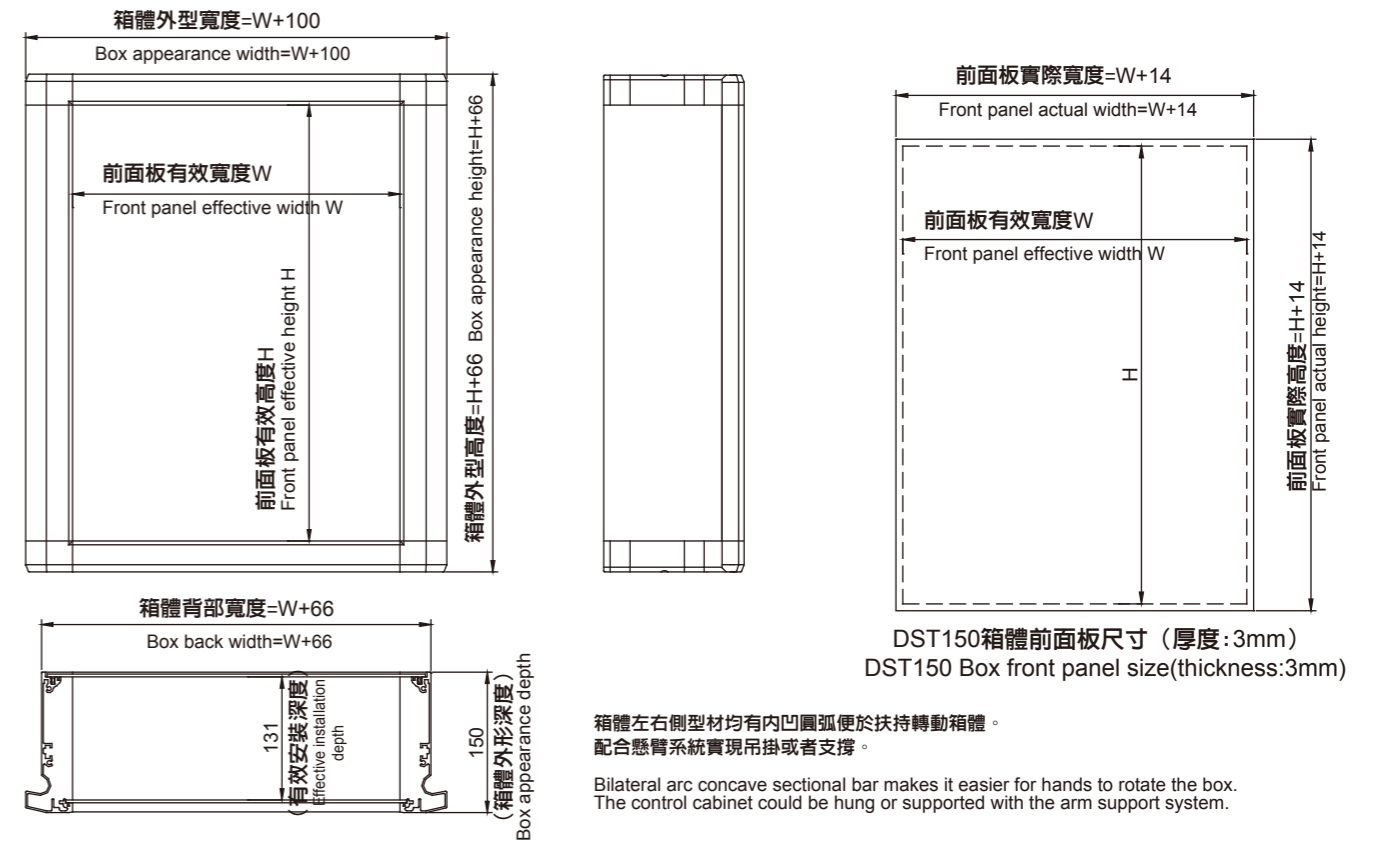

箱體背部線纜（帶插頭）安裝方式
Installation instructions of cables (with a plug) in rear box

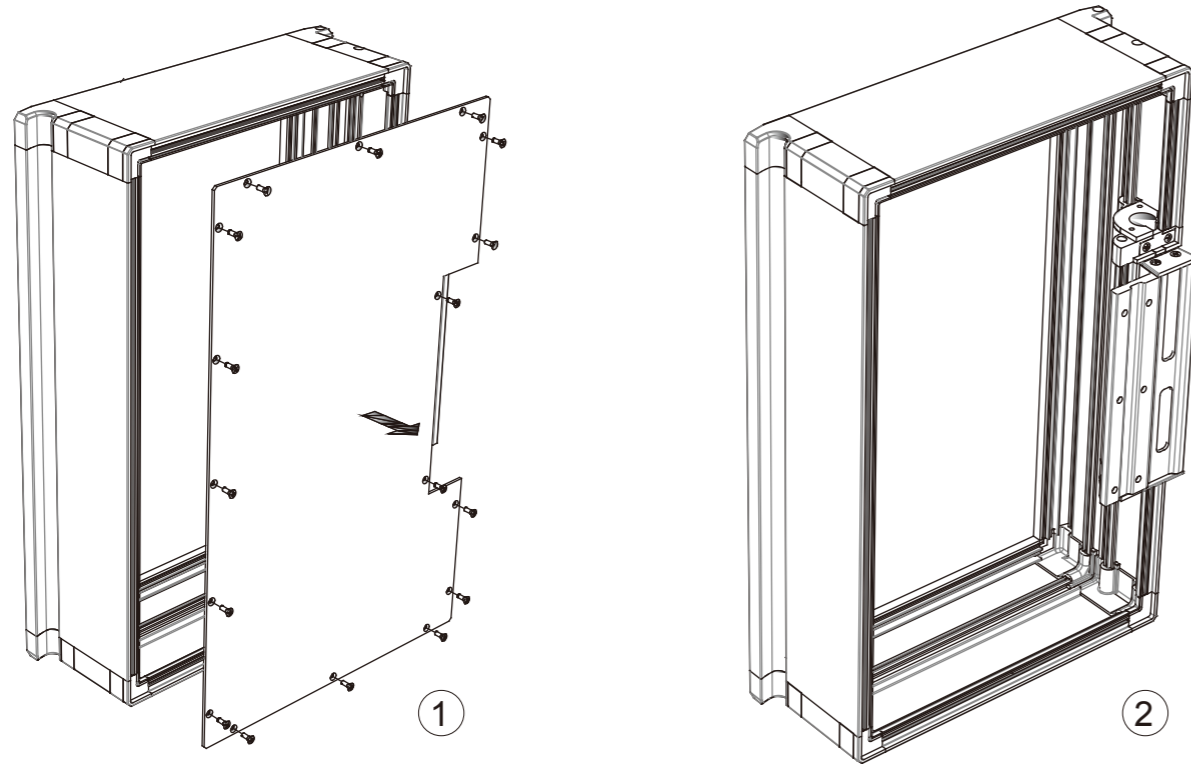

1. 卸下後門板固定螺釘，取下後門板（如圖2）。
Remove the fixing screws on the rear panel to disassemble it.(as figure 2)

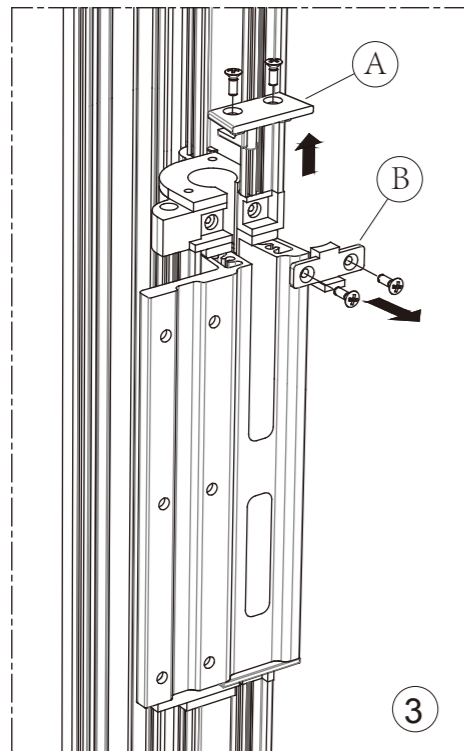

2. 卸下A和B兩個小蓋板。
Remove the two small cover plates A and B.

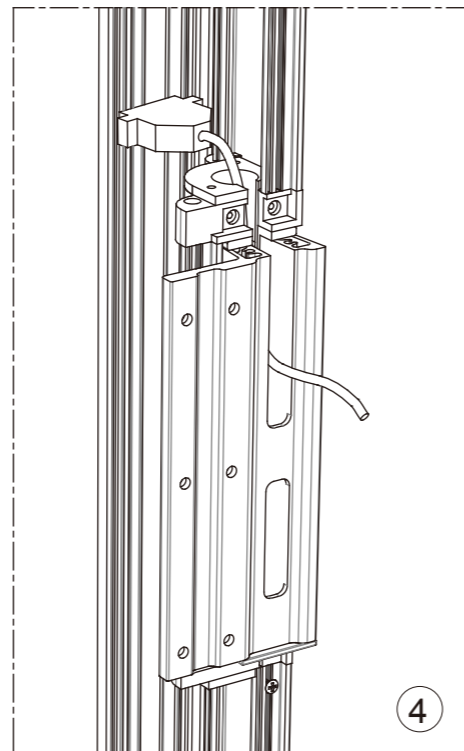

3. 把線纜放入槽口。
Put the cables into the slot.

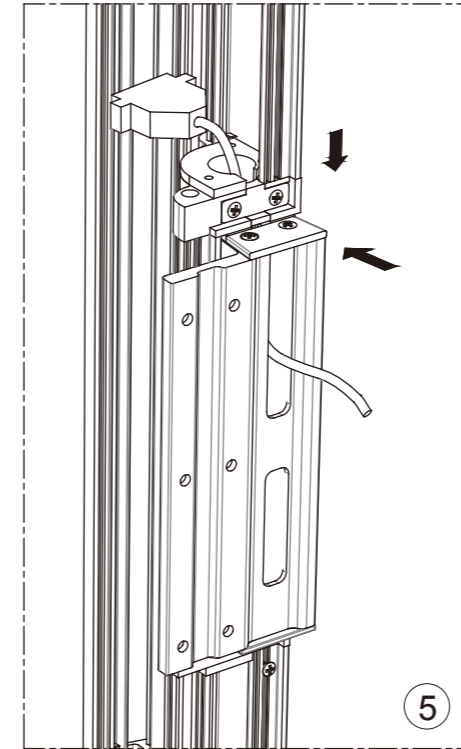

4. 安裝A和B兩個小蓋板。
Install the cover plates A and B.

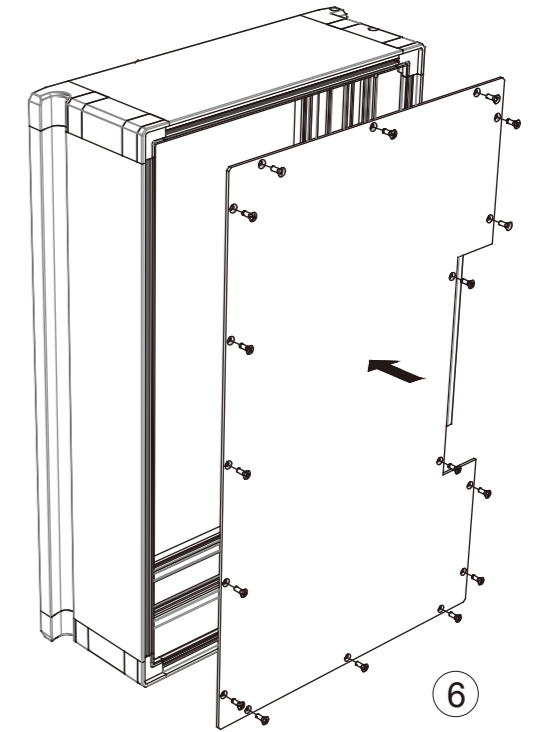

5. 安裝後門板
Install the rear panel.

無插頭線纜走線方式 Routing of the cables without plugs

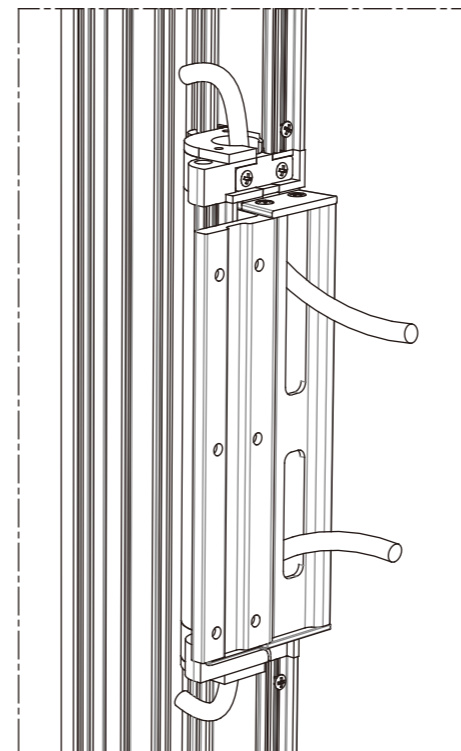

可直接向上或向下穿過轉軸
Upward or downward threading directly through the rotation hinge

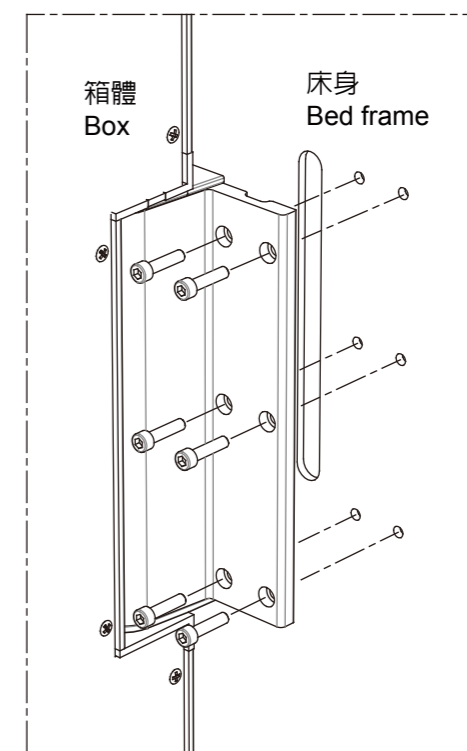

箱體安裝方式（6xM6螺釘）
Installation Method(6xM6 screws)

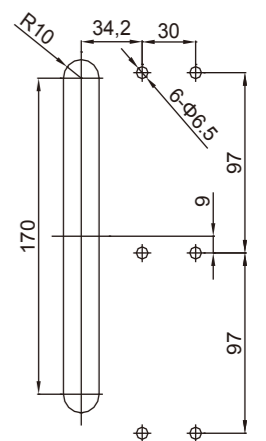

箱體安裝孔尺寸
Mounting hole size of the box

控制箱支架 (外觀專利產品)

Control Cabinet Stand (Products of Patent Exterior)

控制箱支架由高品質陽極氧化鋁型材和鋁壓鑄部件構成。外觀設計簡潔，結構輕盈穩固。立柱部分表面陽極氧化處理，與控制箱體渾然一體，前凸弧度設計形成的向後7度仰角更符合人體工程學原理。底盤部分採用表面深灰色噴塑工藝，符合工業場合需求。

該支架可配合DST210/140，DST200/130，DST155/180系列及其他型號的控制箱體。底盤腳輪或支撐底腳為選配件，可按需要另行訂購。

The control cabinet stand is assembly of superior anodized aluminum section bars and die-casting aluminum corner pieces. The design is concise; the structure lightweight and stable. The anodized pillar blends into one integral whole with the control cabinet. It's forward bulging curve forming a 7° elevation angle conform with ergonomics. The surface of the chassis is plastic-spray dark gray and conforms with industrial requirement.

The stand could go with series of DST210/140, DST200/130, DST155/180 and other types of control cabinets. The caster wheels and support feet are optional parts and could be ordered as required.



基本性能及參數

外形尺寸 (不含腳輪或支撐底腳) :

高 x 寬 x 深 : 1018mm x 600mm x 650mm

材料 :

立柱型材 : 鋁合金6063
 立柱兩端蓋 : 壓鑄鋁合金102
 底盤框架型材 : 鋁合金6063
 底盤角部件 : 壓鑄鋁合金102
 底盤兩側壓條 : PE

顏色 :

立柱 : 陽極氧化鋁本色或噴塑岩石灰色
 立柱兩端蓋 : 噴塑, 岩石灰, 近似RAL7012
 底盤框架 : 噴塑, 岩石灰, 近似RAL7012
 底盤角部件 : 噴塑, 岩石灰, 近似RAL7012

Fundamental characteristics and parameter :

Dimensions (Without caster wheels or support feet)

Height x width x depth : 1018mm x 600mm x 650mm

Material :

The pillar sectional bar: 6063 aluminum alloy
 The lids on both ends of the pillar: 102 die-cast aluminum alloy
 The chassis frame sectional bar : 6063 aluminum alloy
 The chassis corner piece: 102 die-cast aluminum alloy
 The trim strips of the chassis: PE

Color :

Pillar: anodized aluminum color or plastic-spray rock gray
 The lids on both ends of the pillar: plastic-spray rock gray akin to RAL7012
 The chassis frame: plastic-spray rock gray akin to RAL7012
 The chassis corner piece: plastic-spray rock gray akin to RAL7012



控制箱支架

Control Cabinet Stand

外形尺寸

Dimensions :

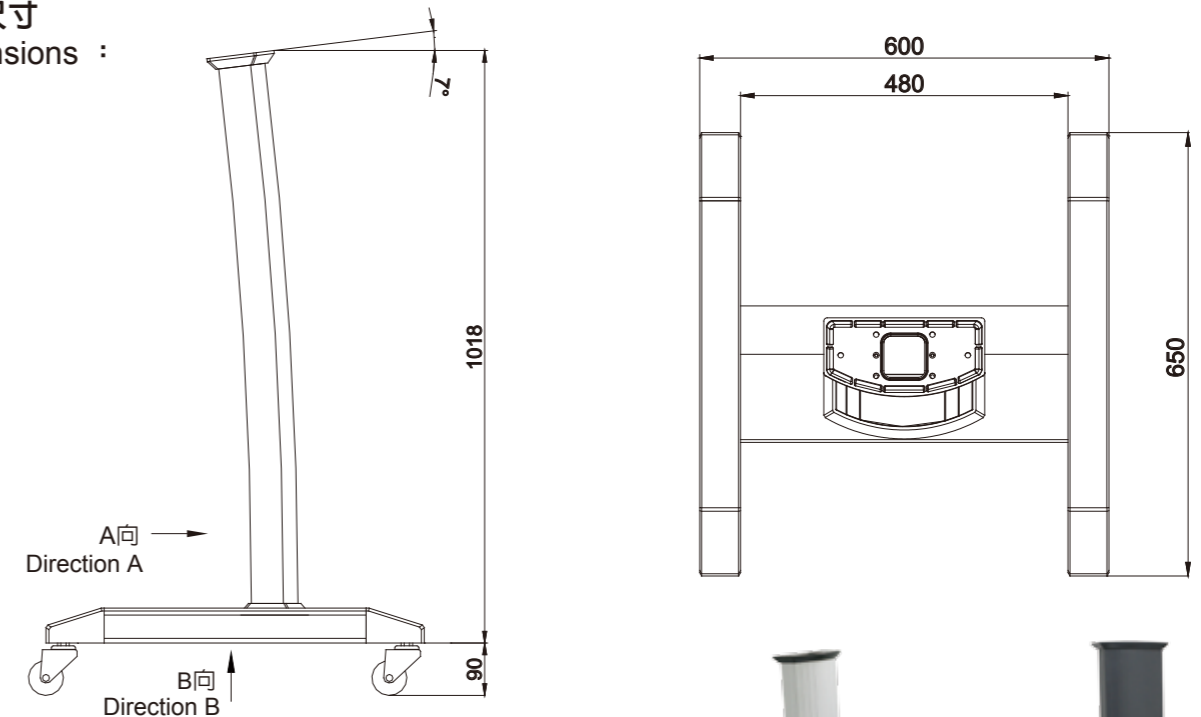

訂貨號 : 支架 : 920.0.000.00 (陽極氧化立柱)

支架 : 920.0.000.01 (鋼灰噴塑立柱)

帶剎車腳輪 : 920.9.100.00 4個/套

支撐底腳 : 920.9.110.00 4個/套

Order NO. Stand: 920.0.000.00(anodised pillar)

Stand: 920.0.000.01

The caster wheels with brakes:

920.9.100.00 plastic-spray steel gray (4 pieces/ set)

The support feet: 920.9.110.00 (4 pieces/ set)



出線方式 : 1. 立柱下方背部 (A向) 出線口, 在側蓋板上開孔安裝軟管接頭。

2. 底部中間 (B向) 出線口, 在底蓋板上開孔安裝90度軟管接頭 (需配裝腳輪或支撐底腳)。

Routing Mode: 1. The outlet under the rear pillar (Direction A): opening hole on the side lid and installing a hose fitting.

2. The outlet in the middle bottom (Direction B): opening hole on the bottom lid and installing a 90° hose fitting.

(The caster wheels or support feet are required)

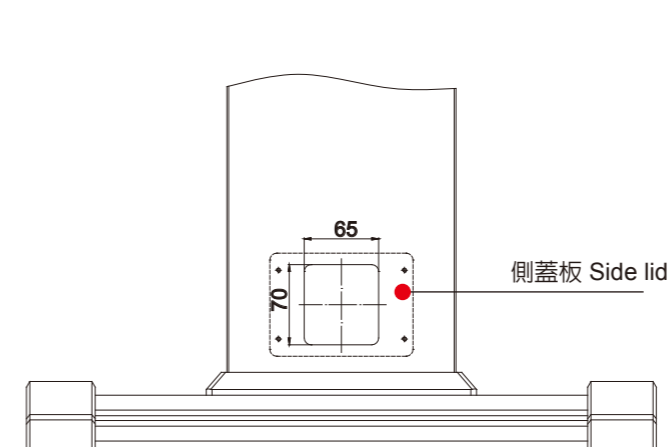

立柱下方背部 A向出線口

The outlet under the rear pillar (Direction A)

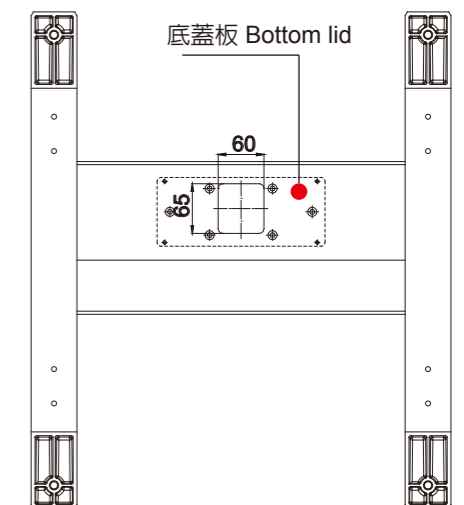

立柱底部 B向出線口

The outlet in the middle bottom (Direction B)

KBS鍵盤托架 The KBS Keyboard Tray

鍵盤托架專為放置鍵盤和滑鼠而設計，採用中空鋁型材，表面陽極氧化處理。兩側由鋁合金壓鑄件與箱體連接。滑鼠板位於右側，可拉出或收起。

該鍵盤托架適用於DST105/155, DST210/140, DST190/120, DST200/130控制箱體。

注：顏色不可更改。

The KBS keyboard tray, made of anodized hollow aluminum sectional bar, is designed for placing the keyboard and the mouse.

It is connected with the box by bilateral aluminum alloy die-castings. The pull-out mouse tray is on the right side. This keyboard tray applies to series of DST105/155, DST210/140, DST190/120, and DST200/130 control cabinets.

Note: color unchanged.



外形尺寸 Dimensions :

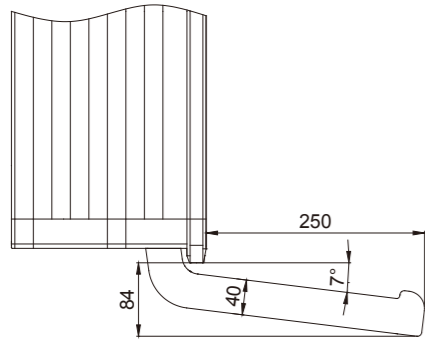

DST210/140 箱體
DST210/140 Box

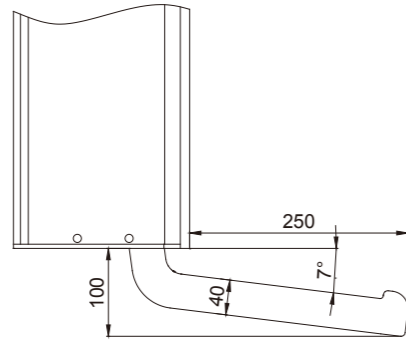

DST190/120 箱體
DST190/120 Box

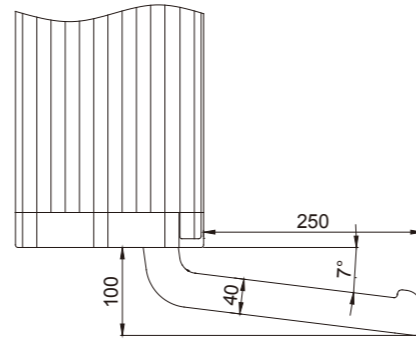

DST200/130 箱體
DST200/130 Box

注：鍵盤架寬度同控制箱體寬度（不含把手）。
Note: The keyboard tray width equals to the box width(Excluding handles)



材質：
鍵盤檯面：鋁型材，鋁合金6063
兩側固定件：壓鑄鋁合金102
滑鼠板：3mm鋁板

顏色：
鍵盤檯面：陽極氧化鋁本色
兩側固定件：岩石灰，近似RAL7012
滑鼠板：岩石灰，近似RAL7012

訂貨號：KBS-01

Material:
Keyboard table: 6063 aluminum alloy
Fixture on both sides: 102 die-cast aluminum alloy
Mouse table: 3mm aluminum sheet

Color:
Keyboard table: anodized aluminum color
Fixture on both sides: rock gray akin to RAL7012
Mouse table: rock gray akin to RAL7012

Order NO. : KBS-01

微型懸臂組件：KL 3550系列 Minisize Support Arm Units: KL 3550 Series



品名：箱體連接件
訂貨號：KL 35-50-3500
重量：0.8kg
材料：壓鑄鋁合金
可水平旋轉0-320°

Name of product : Box connector
Order NO. : KL 35-50-3500
Weight : 0.8kg
Material : die-cast aluminum alloy
0-320° rotatable horizontally

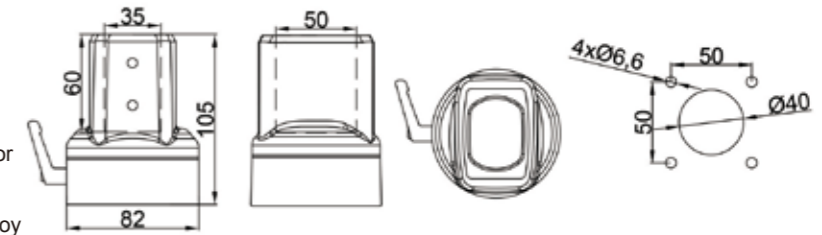

品名：轉角
訂貨號：KL 35-50-3510
重量：0.5kg
材料：壓鑄鋁合金

Name of product : Corner
Order NO. : KL 35-50-3510
Weight : 0.5kg
Material : die-cast aluminum alloy

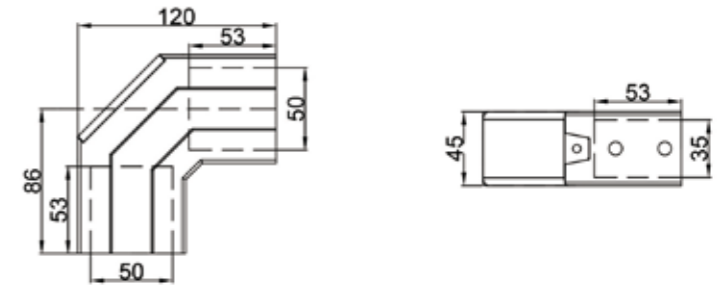

品名：頂座
訂貨號：KL 35-50-3520
重量：1.3kg
材料：壓鑄鋁合金
可水平旋轉0-320°

Name of product : Footstock
Order NO. : KL 35-50-3520
Weight : 1.3kg
Material : die-cast aluminum alloy
0-320° rotatable horizontally

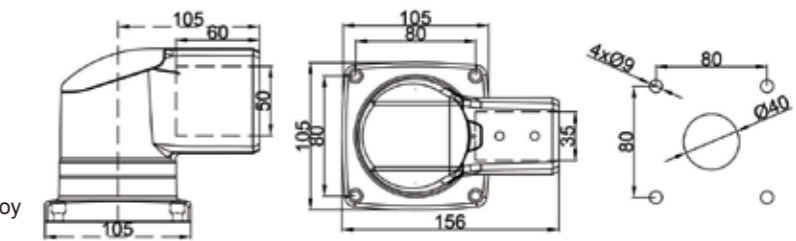

品名：中間連接件
訂貨號：KL 35-50-3530
重量：1.4kg
材料：壓鑄鋁合金
可水平旋轉0-320°

Name of product : Middle connector
Order NO. : KL 35-50-3530
Weight : 1.4kg
Material : die-cast aluminum alloy
0-320° rotatable horizontally

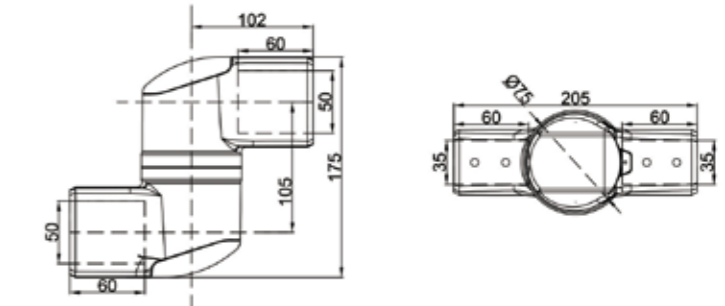

微型懸臂組件：KL 3550系列
Minisize Support Arm Units: KL 3550 Series



品名：固定底座
訂貨號：KL 35-50-3540
重量：0.5kg
材料：壓鑄鋁合金
Name of product : Fixed base
Order NO. : KL 35-50-3540
Weight : 0.5kg
Material : die-cast aluminum alloy

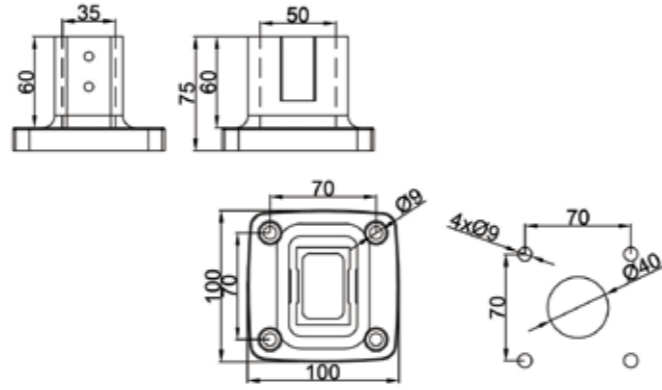

品名：90° 箱體連接件
訂貨號：KL 35-50-3550
重量：1.1kg
材料：壓鑄鋁合金
可水平旋轉0-320°
Name of product : 90° Box connector
Order NO. : KL 35-50-3550
Weight : 1.1kg
Material : die-cast aluminum alloy
0-320° rotatable horizontally

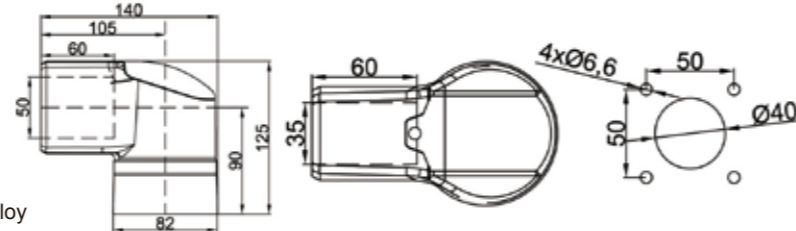

品名：水平牆座
訂貨號：KL 35-50-3560
重量：1.6kg
材料：壓鑄鋁合金
可水平旋轉0-320°
Name of product : Horizontal wall support
Order NO. : KL 35-50-3560
Weight : 1.6kg
Material : die-cast aluminum alloy
0-320° rotatable horizontally

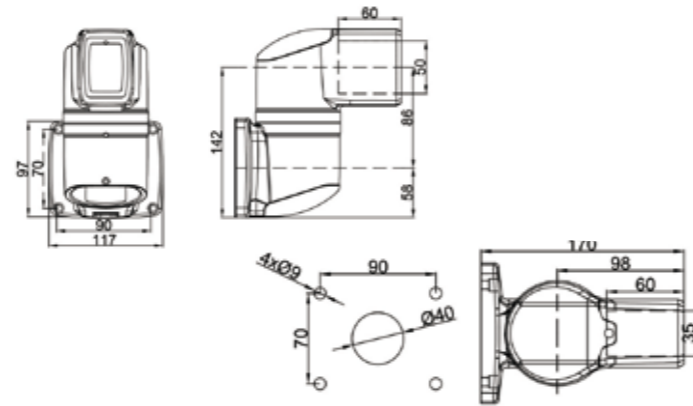

品名：垂直牆座
訂貨號：KL 35-50-3570
重量：1.3kg
材料：壓鑄鋁合金
可水平旋轉0-320°
Name of product : Vertical wall support
Order NO. : KL 35-50-3570
Weight : 1.3kg
Material : die-cast aluminum alloy
0-320° rotatable horizontally

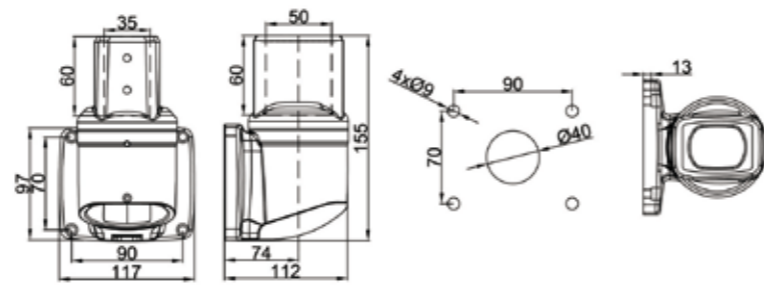

微型懸臂組件：KL 3550系列
Minisize Support Arm Units: KL 3550 Series



品名：可旋轉底座
訂貨號：KL 35-50-3580
重量：0.95kg
材料：壓鑄鋁合金
可水平旋轉0-320°
Name of product : Base
Order NO. : KL 35-50-3580
Weight : 0.95kg
Material : die-cast aluminum alloy
0-320° rotatable horizontally

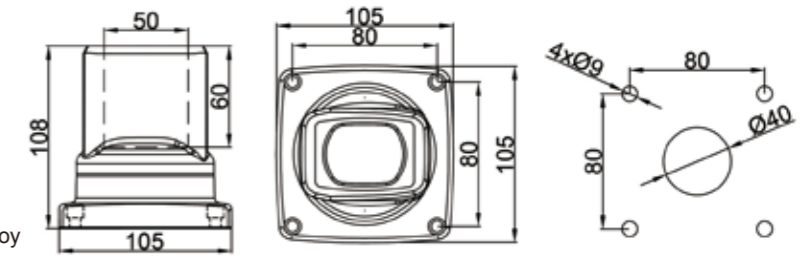

品名：旋轉轉角
訂貨號：KL 35-50-3590
重量：1.1kg
材料：壓鑄鋁合金
可水平旋轉0-320°
Name of product : Rotatable corner
Order NO. : KL 35-50-3590
Weight : 1.1kg
Material : die-cast aluminum alloy
0-320° rotatable horizontally

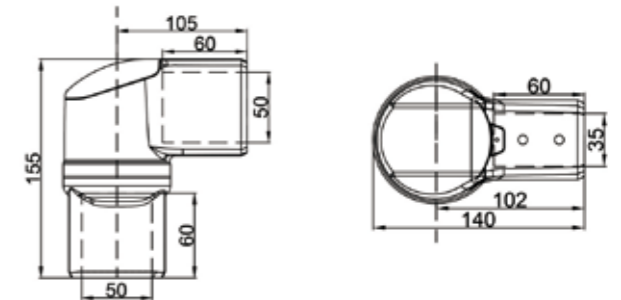
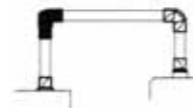

品名：可旋轉箱底座
訂貨號：KL 35-50-3900
重量：1.1kg
材料：壓鑄鋁合金
Name of product : Rotatable box base
Order NO. : KL 35-50-3900
Weight : 1.1kg
Material : die-cast aluminum alloy

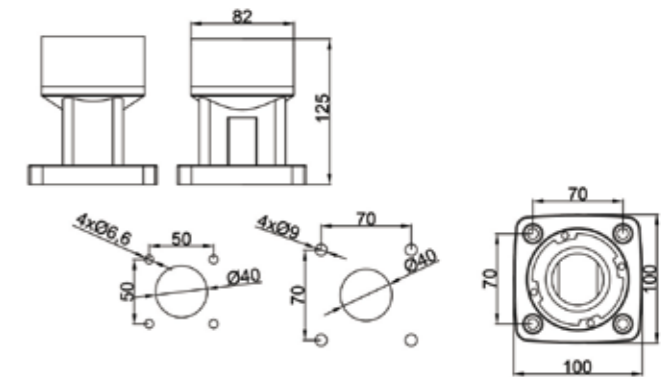

品名：3550連接管
重量：1.8Kg/m
材料：鋁合金
Name of product : 3550 connecting tube
Weight : 1.8Kg/m
Material : aluminum alloy

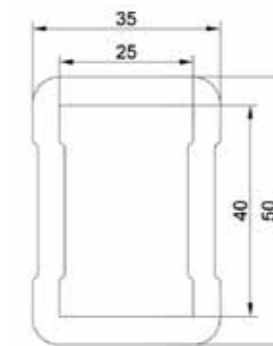

鋁管長度 Length	訂貨號 Order NO.
0.25mm	35-50-250-35
0.5mm	35-50-500-35
1mm	35-50-1000-35
1.5mm	35-50-1500-35



該系列輕型懸臂組件配合44x60mm鋁管，用於懸掛或支撐小型控制箱體。鋁管表面採用噴塑處理，組件全部採用鋁合金壓鑄工藝製造，在保證強度及合理的結構下，更注重了外觀的特有風格。

The series of lightweight support arm units matching 44x60mm aluminum tubes are used to hang or support small control cabinets. The surface of the aluminum tubes is plastic spray, and all the support arm units are made of die-casting aluminum alloy. They possess sturdiness, reasonable structure, and unique style of appearance.



品名：箱體連接件
 訂貨號：440.6.090.00
 重量：0.9kg
 材料：壓鑄鋁合金
 可水平旋轉 0-320°

Name of product : Box connector
 Order NO. : 440.6.090.00
 Weight : 0.9kg
 Material : die-casting aluminum alloy
 0-320° rotatable horizontally

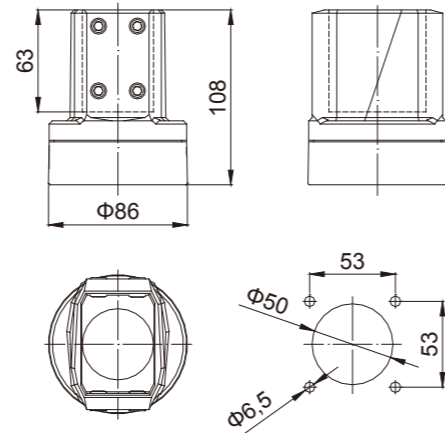
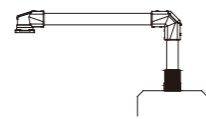

品名：90° 箱體連接件
 訂貨號：440.6.150.00
 重量：1.1kg
 材料：壓鑄鋁合金
 可水平旋轉 0-320°

Name of product : 90° box connector
 Order NO. : 440.6.150.00
 Weight : 1.1kg
 Material : die-casting aluminum alloy
 0-320° rotatable horizontally

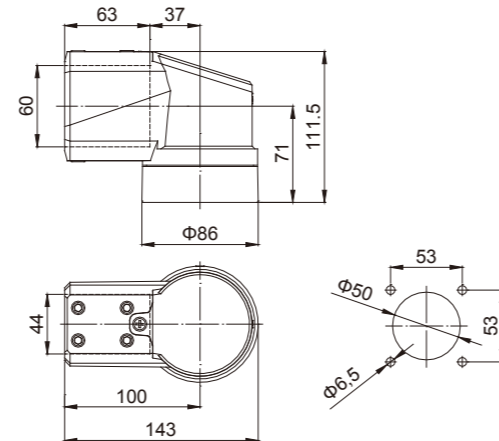

品名：90° 轉角
 訂貨號：440.6.100.00
 重量：1.06kg
 材料：壓鑄鋁合金

Name of product : 90° corner
 Order NO. : 440.6.100.00
 Weight : 1.06kg
 Material : die-casting aluminum alloy

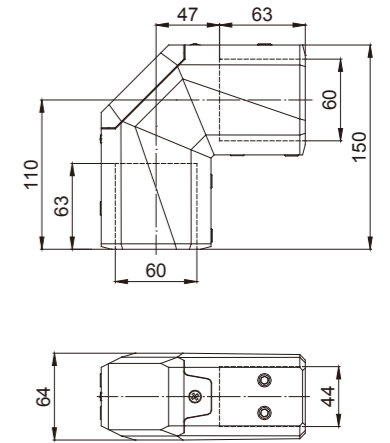
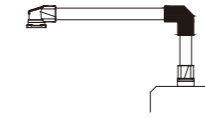

品名：頂座
 訂貨號：440.6.120.00
 重量：1.13kg
 材料：壓鑄鋁合金
 可水平旋轉 0-320°

Name of product : Footstock
 Order NO. : 440.6.120.00
 Weight : 1.13kg
 Material : die-casting aluminum alloy
 0-320° rotatable horizontally

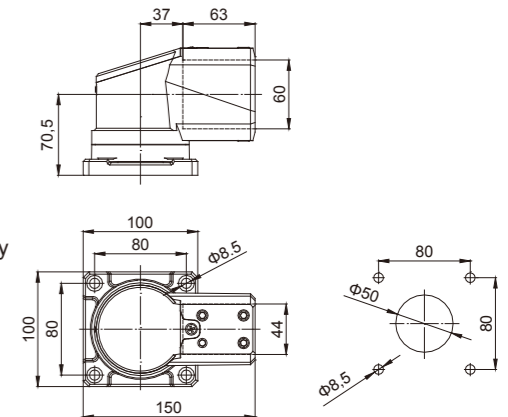

品名：水平牆座
 訂貨號：440.6.110.00
 重量：1.36kg
 材料：壓鑄鋁合金
 可水平旋轉 0-320°

Name of product : Horizontal wall support
 Order NO. : 440.6.110.00
 Weight : 1.36kg
 Material : die-casting aluminum alloy
 0-320° rotatable horizontally

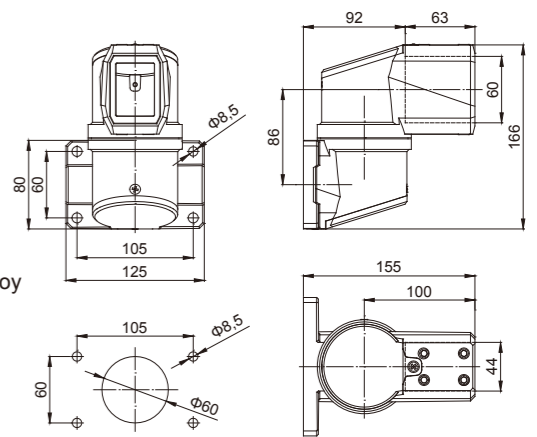

品名：中間連接件
 訂貨號：440.6.130.00
 重量：1.52kg
 材料：壓鑄鋁合金
 可水平旋轉 0-320°

Name of product : Middle connector
 Order NO. : 440.6.130.00
 Weight : 1.52kg
 Material : die-casting aluminum alloy
 0-320° rotatable horizontally

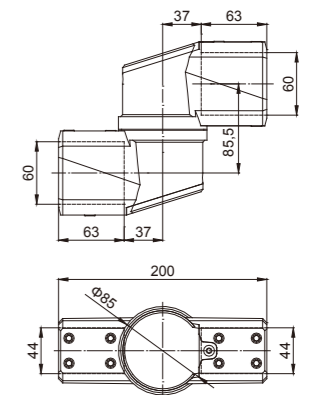
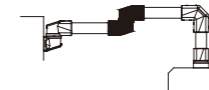



品名：垂直牆座
訂貨號：440.6.170.00
重量：1.17kg
材料：壓鑄鋁合金
可水平旋轉 0-320°

Name of product : Vertical wall support
Order NO. : 440.6.170.00
Weight : 1.17kg
Material : die-casting aluminum alloy
0-320° rotatable horizontally

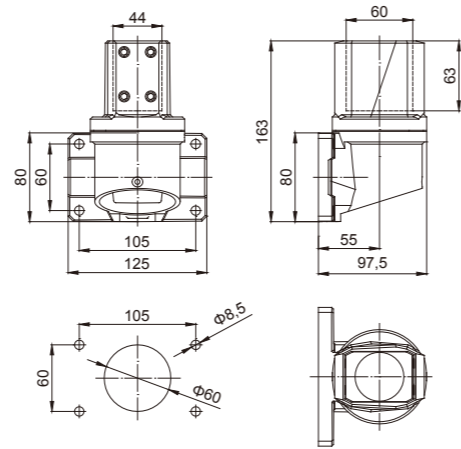

品名：固定底座
訂貨號：440.6.140.00
重量：0.5kg
材料：壓鑄鋁合金

Name of product : Fixed base
Order NO. : 440.6.140.00
Weight : 0.5kg
Material : die-casting aluminum alloy

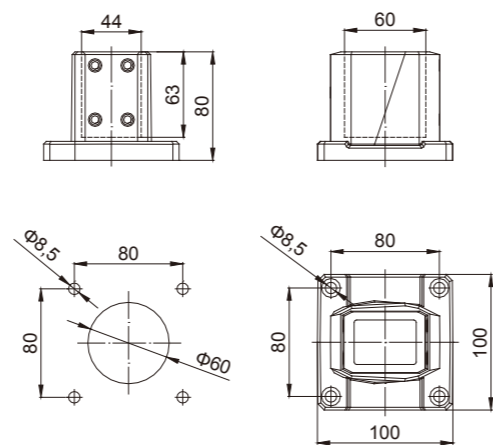
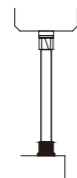

品名：可旋轉底座
訂貨號：440.6.180.00
重量：0.94kg
材料：壓鑄鋁合金
可水平旋轉 0-320°

Name of product : Rotatable base
Order NO. : 440.6.180.00
Weight : 0.94kg
Material : die-casting aluminum alloy
0-320° rotatable horizontally

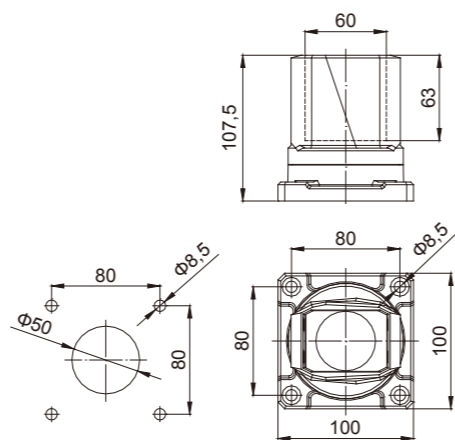
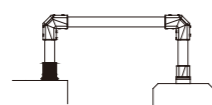

品名：可旋轉 90° 轉角
訂貨號：440.6.190.00
重量：1.32kg
材料：壓鑄鋁合金
可水平旋轉 0-320°

Name of product : Rotatable 90° corner
Order NO. : 440.6.190.00
Weight : 1.32kg
Material : die-casting aluminum alloy
0-320° rotatable horizontally

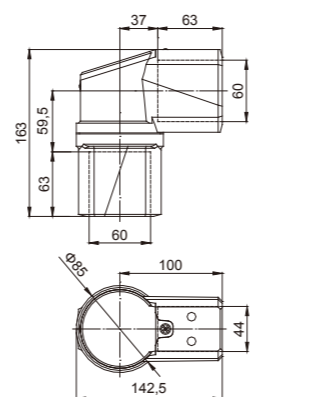

品名：可旋轉箱底座
訂貨號：440.6.160.00
重量：0.95kg
材料：壓鑄鋁合金

Name of product : Rotatable box base
Order NO. : 440.6.160.00
Weight : 0.95kg
Material : die-casting aluminum alloy

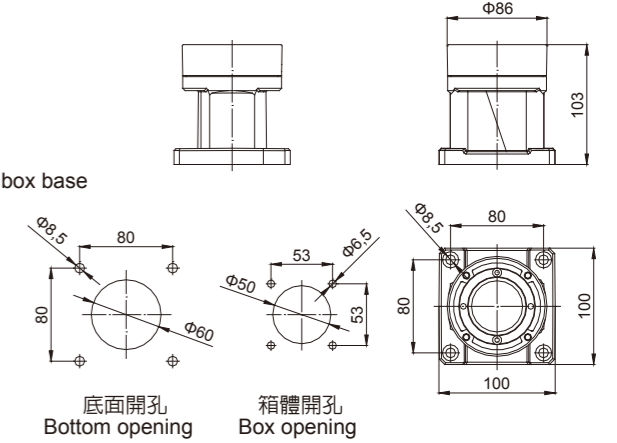
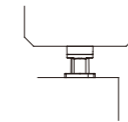

品名：8° 傾斜箱座
訂貨號：440.6.080.00
重量：0.89kg
材料：壓鑄鋁合金

Name of product : 8° tilting box base
Order NO. : 440.6.080.00
Weight : 0.89kg
Material : die-casting aluminum alloy

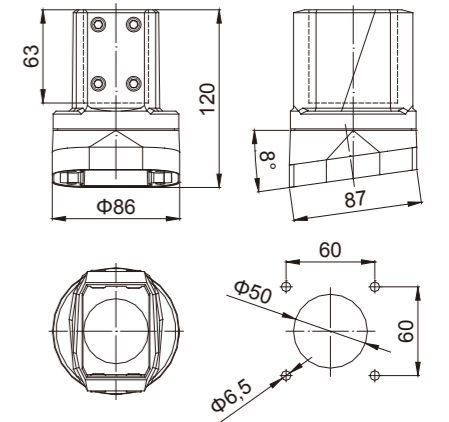

品名：15° 斜面連接件
訂貨號：440.6.200.00
重量：0.35kg
材料：壓鑄鋁合金

Name of product : 15° tilting connector
Order NO. : 440.6.200.00
Weight : 0.35kg
Material : die-casting aluminum alloy

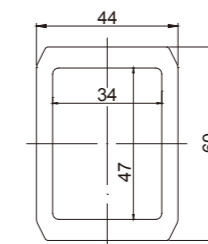
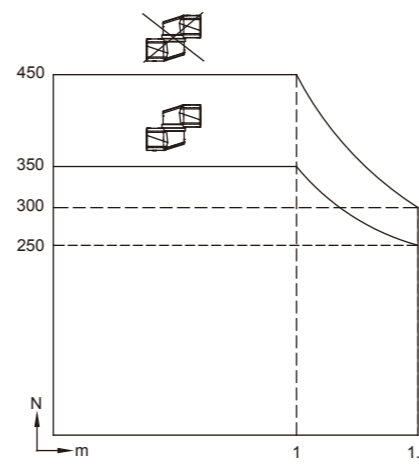
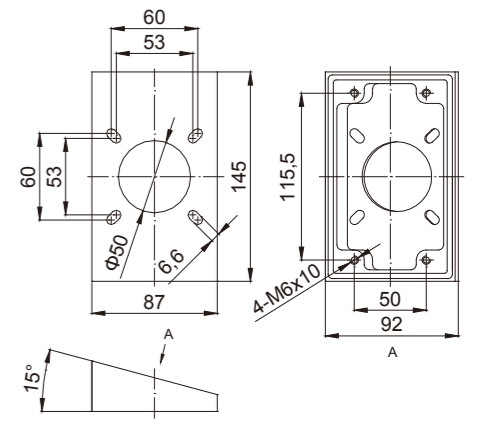
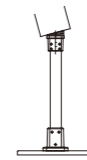

4460 鋁管規格表 (配 4460 輕型懸臂)
Size table of 4460 aluminum tubes
(for 4460 lightweight support arms)

鋁管長度 Length	訂貨號 Order NO.
0.25mm	440.6.025.44
0.5mm	440.6.050.44
1mm	440.6.100.44
1.5mm	440.6.150.44
2mm	440.6.200.44



該系列中型懸臂組件配合55x75mm鋁管，用於懸掛或支撐控制箱體。鋁管表面採用噴塑處理，組件全部採用鋁合金壓鑄工藝製造，在保證強度及合理的結構下，更注重了外觀的特有風格。

The series of medium support arm units matching 55x75mm aluminum tubes are used to hang or support control cabinets. The surface of the aluminum tubes is plastic spray, and all the support arm units are made of die-casting aluminum alloy. They possess sturdiness, reasonable structure, and unique style of appearance.



品名：箱體連接件
訂貨號：550.7.090.00
重量：1.8kg
材料：壓鑄鋁合金
可水平旋轉 0-320°

Name of product : Box connector
Order NO. : 550.7.090.00
Weight : 1.8kg
Material : die-casting aluminum alloy
0-320° rotatable horizontally

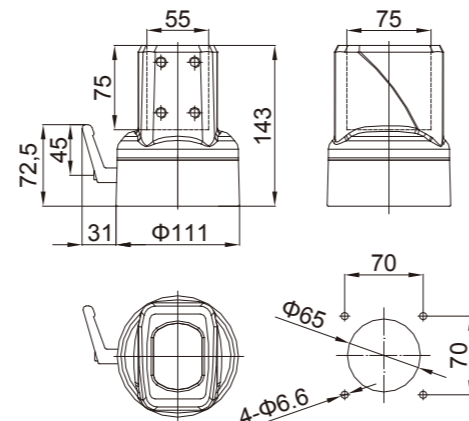
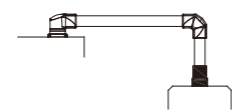

品名：90° 箱體連接件
訂貨號：550.7.150.00
重量：2.6kg
材料：壓鑄鋁合金
可水平旋轉 0-320°

Name of product : 90° box connector
Order NO. : 550.7.150.00
Weight : 2.6kg
Material : die-casting aluminum alloy
0-320° rotatable horizontally

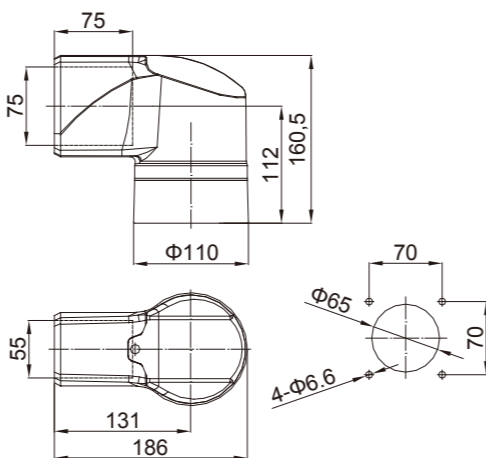
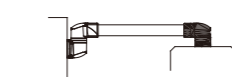

品名：90° 轉角
訂貨號：550.7.100.00
重量：1.3kg
材料：壓鑄鋁合金

Name of product : 90° corner
Order NO. : 550.7.100.00
Weight : 1.3kg
Material : die-casting aluminum alloy

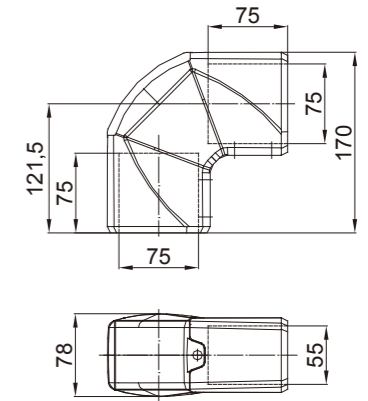
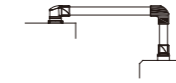

品名：頂座
訂貨號：550.7.120.00
重量：2.7kg
材料：壓鑄鋁合金
可水平旋轉 0-320°
可限位（請諮詢）

Name of product : Footstock
Order NO. : 550.7.120.00
Weight : 2.7kg
Material : die-casting aluminum alloy
0-320° rotatable horizontally;
rotation degree could be limited as
required. please consult us.

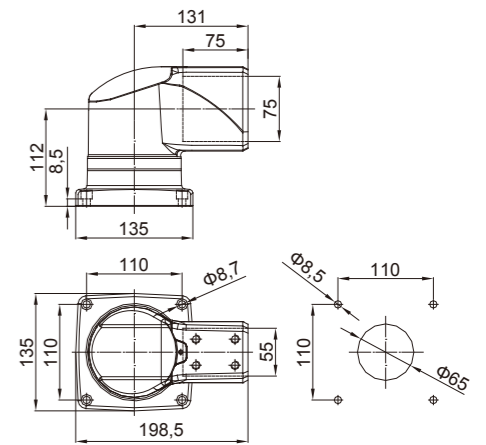

品名：水平牆座
訂貨號：550.7.110.00
重量：3.3kg
材料：壓鑄鋁合金
可水平旋轉 0-320°
可限位（請諮詢）

Name of product : Horizontal wall support
Order NO. : 550.7.110.00
Weight : 3.3kg
Material : die-casting aluminum alloy
0-320° rotatable horizontally;
rotation degree could be limited as
required. please consult us.

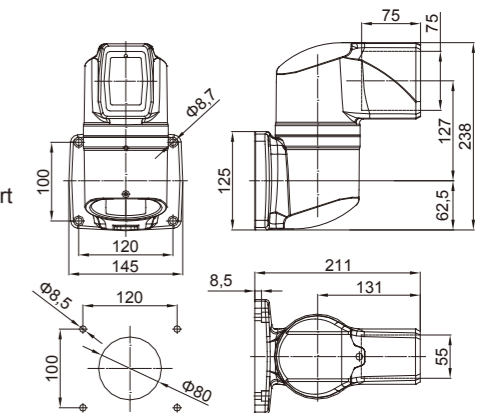

品名：中間連接件
訂貨號：550.7.130.00
重量：3.4kg
材料：壓鑄鋁合金
可水平旋轉 0-320°

Name of product : Middle connector
Order NO. : 550.7.130.00
Weight : 3.4kg
Material : die-casting aluminum alloy
0-320° rotatable horizontally

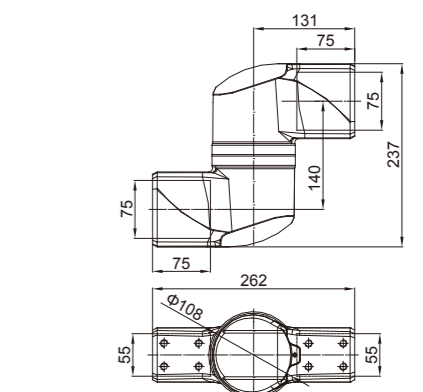

5575 系列 中型懸臂組件
5575 Series Medium Support Arm Units



品名：垂直牆座
訂貨號：550.7.170.00
重量：2.6kg
材料：壓鑄鋁合金
可水平旋轉 0-320°

Name of product : Vertical wall support
Order NO. : 550.7.170.00
Weight : 2.6kg
Material : die-casting aluminum alloy
0-320° rotatable horizontally

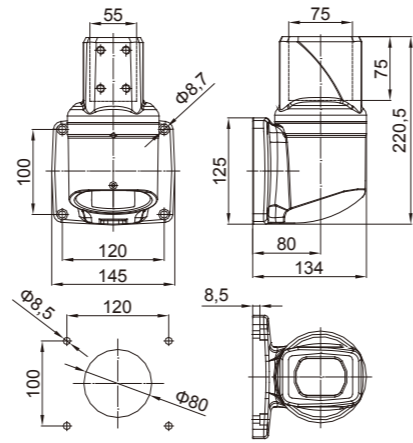

品名：固定底座
訂貨號：550.7.140.00
重量：0.83kg
材料：壓鑄鋁合金

Name of product : Fixed base
Order NO. : 550.7.140.00
Weight : 0.83kg
Material : die-casting aluminum alloy

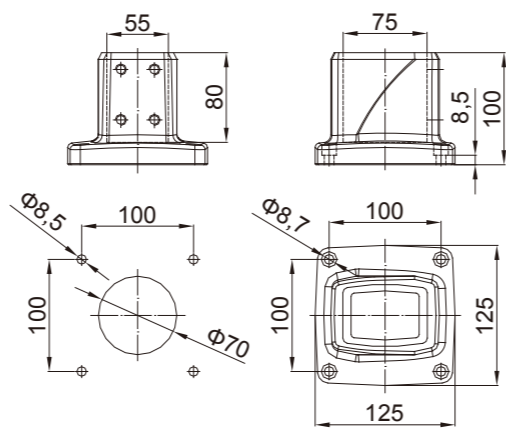

品名：可旋轉底座
訂貨號：550.7.180.00
重量：2.0kg
材料：壓鑄鋁合金
可水平旋轉 0-320°

Name of product : Rotatable base
Order NO. : 550.7.180.00
Weight : 2.0kg
Material : die-casting aluminum alloy
0-320° rotatable horizontally

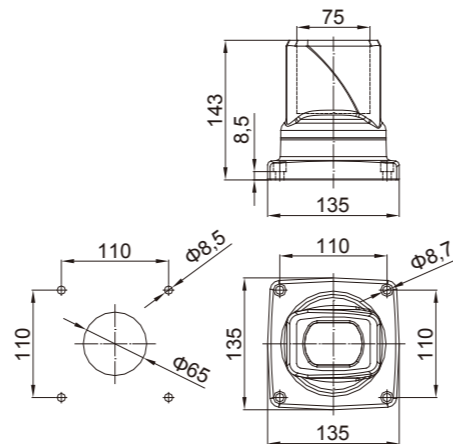
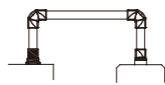

品名：可旋轉 90° 轉角
訂貨號：550.7.190.00
重量：2.7kg
材料：壓鑄鋁合金
可水平旋轉 0-320°

Name of product : Rotatable 90° corner
Order NO. : 550.7.190.00
Weight : 2.7kg
Material : die-casting aluminum alloy
0-320° rotatable horizontally

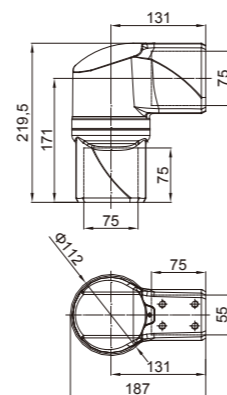

5575 系列 中型懸臂組件
5575 Series Medium Support Arm Units



品名：可旋轉箱底座
訂貨號：550.7.160.00
重量：1.9kg
材料：壓鑄鋁合金

Name of product : Rotatable box base
Order NO. : 550.7.160.00
Weight : 1.9kg
Material : die-casting aluminum alloy

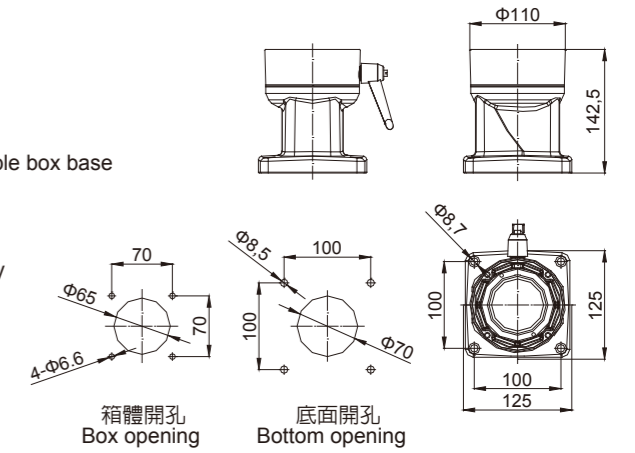
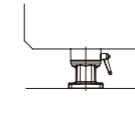

品名：防顫箱座
訂貨號：550.7.080.00
重量：2.56kg
材料：壓鑄鋁合金

Name of product : Anti-vibration box base
Order NO. : 550.7.080.00
Weight : 2.56kg
Material : die-casting aluminum alloy

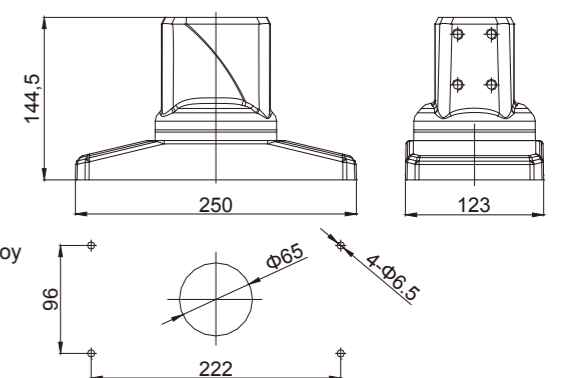
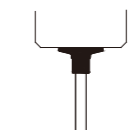

品名：防顫箱座
訂貨號：550.7.085.00
重量：2.78kg
材料：壓鑄鋁合金

Name of product : Anti-vibration box base
Order NO. : 550.7.085.00
Weight : 2.78kg
Material : die-casting aluminum alloy

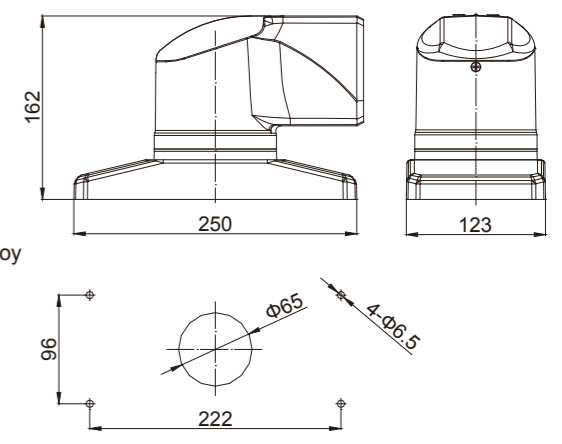
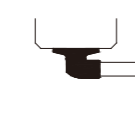

品名：15° 斜面連接件
訂貨號：800.8.160.00
重量：0.45kg
材料：壓鑄鋁合金

Name of product : 15° tilting connector
Order NO. : 800.8.160.00
Weight : 0.45kg
Material : die-casting aluminum alloy

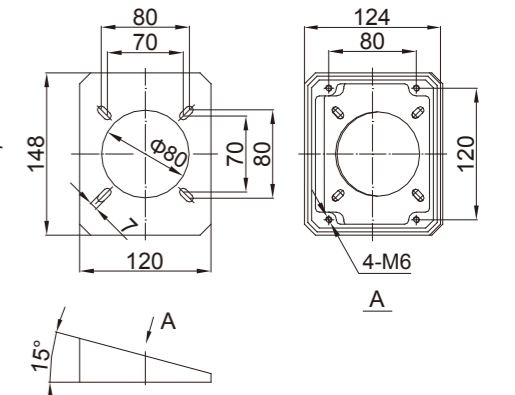

5575 系列 中型懸臂組件
5575 Series Medium Support Arm Units

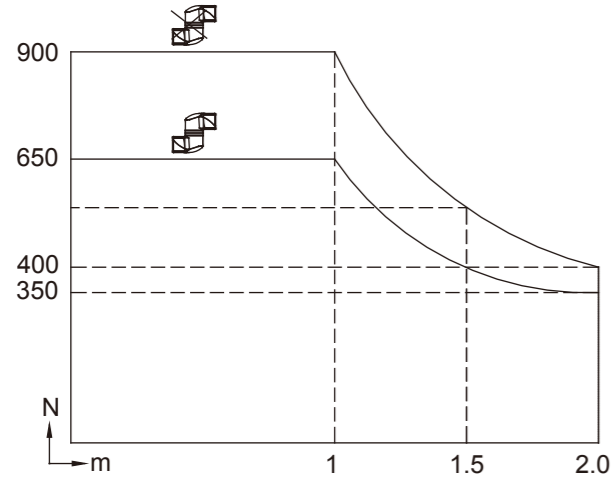

5575鋁管規格表(配5575中型懸臂) :
Size table of 5575 aluminum tubes
(for 5575 medium support arms)

鋁管長度Length	訂貨號Order NO.
0.25 m	550.7.025.55
0.5 m	550.7.050.55
1 m	550.7.100.55
1.5 m	550.7.150.55
2 m	550.7.200.55

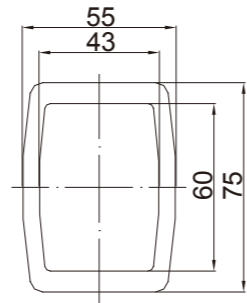

5575開口鋁管 5575 Placketing aluminum tube :

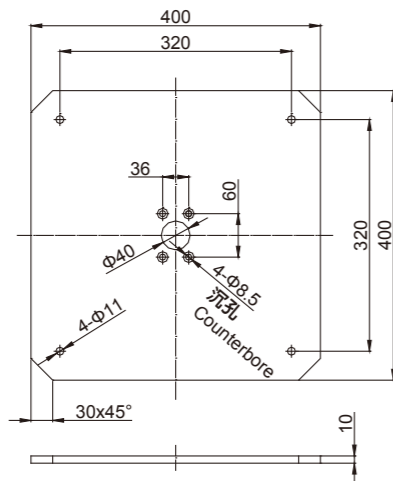

底盤安裝尺寸
Installation size of the bottom plate

訂貨號 :
高度 1 m : 550.7.986.00
高度 1.1m : 550.7.987.00
Order No. :
Height 1 m : 550.7.986.00
Height 1.1m : 550.7.987.00



鋁蓋條
Aluminum cover strip

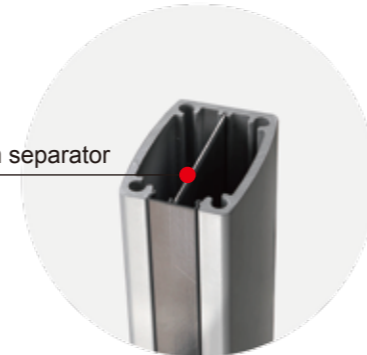

鋁分隔條
Aluminum separator





該系列懸臂組件配合60x85mm鋁管，用於懸掛或支撐中大型控制箱體。鋁管表面採用噴塑處理，組件全部採用鋁合金壓鑄工藝製造，鋁管連接處均採用螺釘固定，結構簡潔，可靠安全，外觀和顏色自成系列。

The series of support arm units matching 60x85mm aluminum tubes are used to hang or support the medium control cabinets. The surface of the aluminum tubes is plastic spray, and all the support arm units are made of die-casting aluminum alloy. Each connecting part of aluminum tubes is fixed with screws. The structure is concise, stable, and safe; exterior and color are in series.



品名：箱體連接件
訂貨號：600.8.090.00
重量：0.77kg
材料：壓鑄鋁合金
可水平旋轉 0-320°
Name of product : Box connector
Order NO. : 600.8.090.00
Weight : 0.77kg
Material : die-casting aluminum alloy
0-320° rotatable horizontally

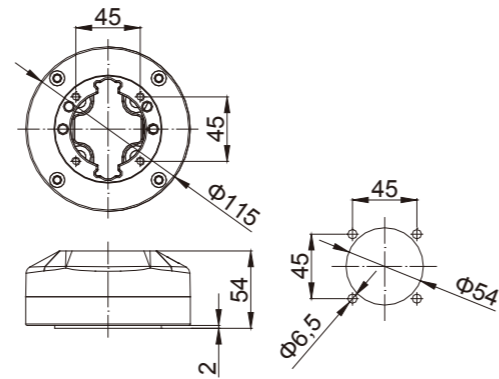
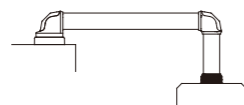

品名：90°箱體連接件
訂貨號：600.8.150.00
重量：2.33kg
材料：壓鑄鋁合金
可水平旋轉 0-320°
Name of product : 90° box connector
Order NO. : 600.8.150.00
Weight : 2.33kg
Material : die-casting aluminum alloy
0-320° rotatable horizontally

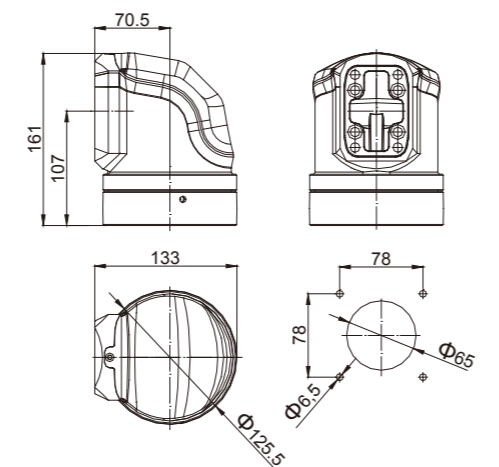
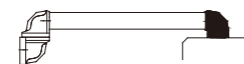

品名：90°轉角
訂貨號：600.8.100.00
重量：0.6kg
材料：壓鑄鋁合金

Name of product : 90° corner
Order NO. : 600.8.100.00
Weight : 0.6kg
Material : die-casting aluminum alloy

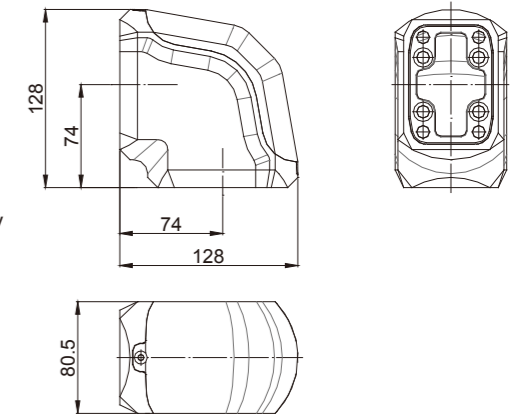
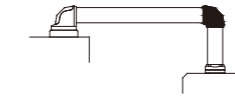

品名：頂座
訂貨號：600.8.120.00
重量：2.63kg
材料：壓鑄鋁合金
可水平旋轉 0-320°

Name of product : Footstock
Order NO. : 600.8.120.00
Weight : 2.63kg
Material : die-casting aluminum alloy
0-320° rotatable horizontally

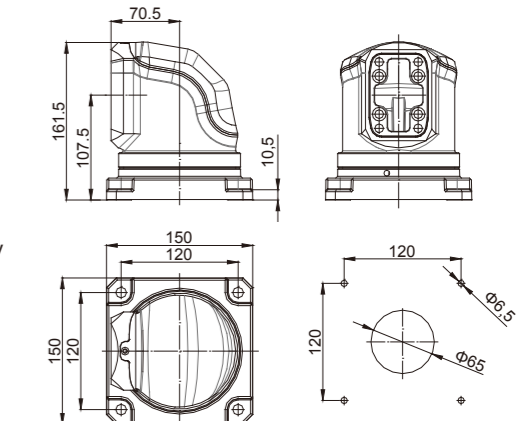
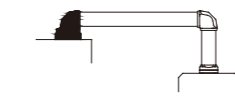

品名：水平牆座
訂貨號：600.8.110.00
重量：3.26kg
材料：壓鑄鋁合金
可水平旋轉 0-320°

Name of product : Horizontal wall support
Order NO. : 600.8.110.00
Weight : 3.26kg
Material : die-casting aluminum alloy
0-320° rotatable horizontally

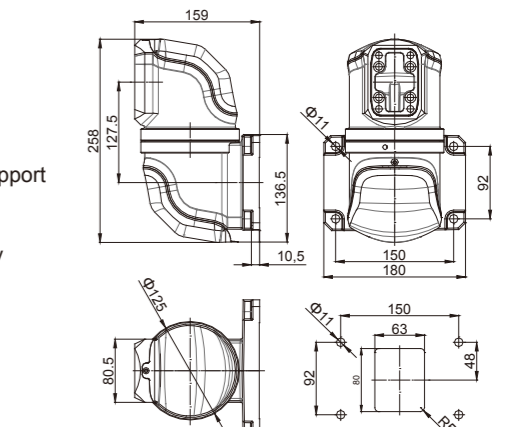
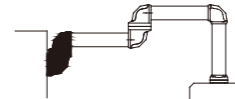

品名：中間連接件
訂貨號：600.8.130.00
重量：2.77kg
材料：壓鑄鋁合金
可水平旋轉 0-320°

Name of product : Middle connector
Order NO. : 600.8.130.00
Weight : 2.77kg
Material : die-casting aluminum alloy
0-320° rotatable horizontally

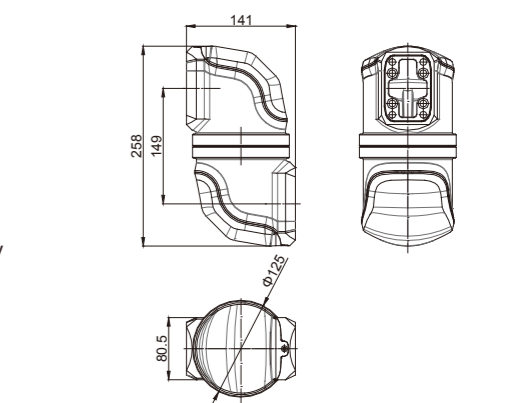
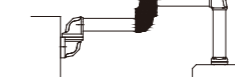



品名：垂直牆座
訂貨號：600.8.170.00
重量：3.24kg
材料：壓鑄鋁合金
可水平旋轉 0-320°

Name of product : Vertical wall support
Order NO. : 600.8.170.00
Weight : 3.24kg
Material : die-casting aluminum alloy
0-320° rotatable horizontally

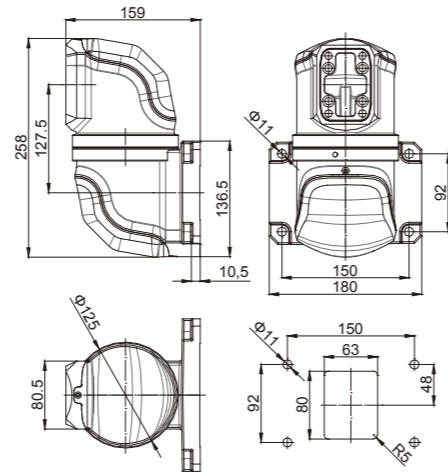

品名：固定底座
訂貨號：600.8.140.00
重量：0.59kg
材料：壓鑄鋁合金

Name of product : Fixed base
Order NO. : 600.8.140.00
Weight : 0.59kg
Material : die-casting aluminum alloy

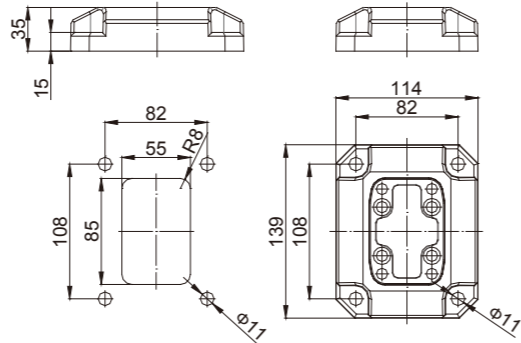
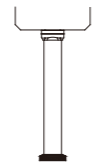

品名：可旋轉底座
訂貨號：600.8.180.00
重量：2.62kg
材料：壓鑄鋁合金
可水平旋轉 0-320°

Name of product : Rotatable base
Order NO. : 600.8.180.00
Weight : 2.62kg
Material : die-casting aluminum alloy
0-320° rotatable horizontally

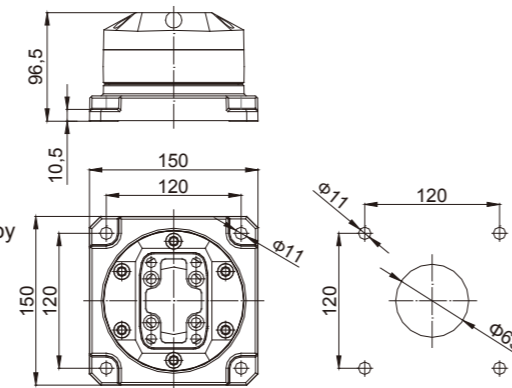
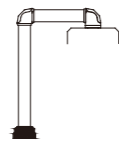

品名：可旋轉 90° 轉角
訂貨號：600.8.190.00
重量：2.7kg
材料：壓鑄鋁合金
可水平旋轉 0-320°

Name of product : Rotatable 90° corner
Order NO. : 600.8.190.00
Weight : 2.7kg
Material : die-casting aluminum alloy
0-320° rotatable horizontally

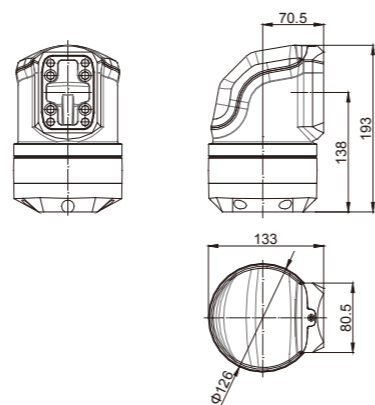

品名：70/100-60/85轉接件
訂貨號：600.8.700.00
重量：0.27kg
材料：壓鑄鋁合金

Name of product :
Adaptor of 70100 and 6085
Order NO. : 600.8.700.00
Weight : 0.27kg
Material : die-casting aluminum alloy

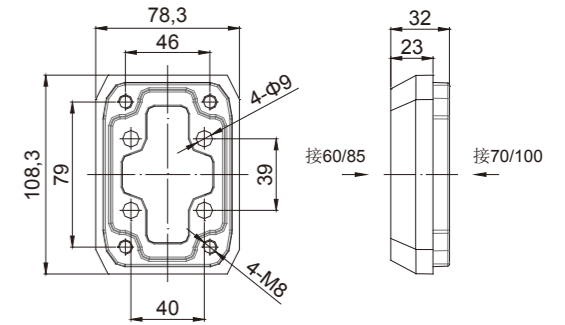
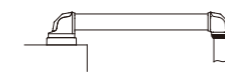

60-85鋁管
6085 Aluminum tube

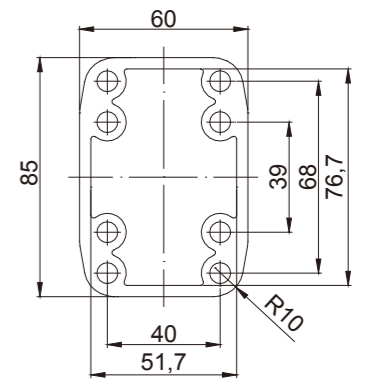
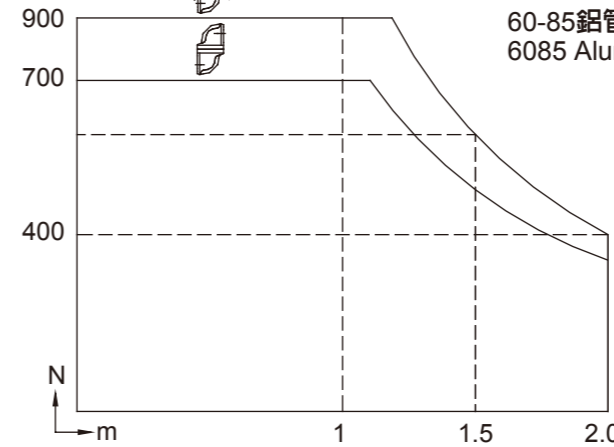

6085鋁管規格表(配6085懸臂):
Size table of 6085 aluminum tubes
(for 6085 support arms)

鋁管長度Length	訂貨號Order NO.
0.25 m	600.8.025.60
0.5 m	600.8.050.60
1 m	600.8.100.60
1.5 m	600.8.150.60
2 m	600.8.200.60

60-85水平鋁管安裝方法：
在把鋁管連接到懸臂接頭之前，先把2個圓頭調節螺釘旋緊在鋁管兩端面上（如圖位置）。

Installation method for 6085 horizontal aluminum tube:
Tighten 2 round-head adjusting screws onto the end face of the aluminum tube before connecting the tube to the joints of the support arm.(see the picture)

按如圖所示，同時調節2個圓頭螺釘，根據整個懸臂系統承重不同旋出一定距離（1~5mm），使水平段連接管上抬一定角度。

Adjust these 2 round-head screws as the picture, and then rotate a certain distance (1~5mm) according to the individual loading of the support arm, lifting the horizontal tube up to a certain angle.

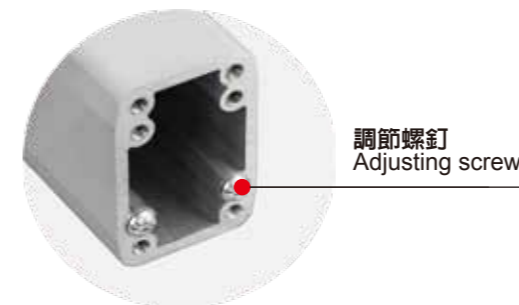

調節螺釘
Adjusting screw

調節連接管水平度
Adjusting levelness of the connecting tube

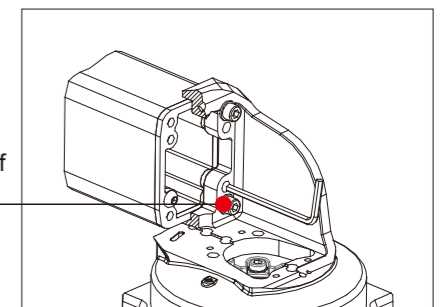



該系列懸臂組件配合70x100mm鋁管，用於懸掛或支撐中大型控制箱體。鋁管表面採用噴塑處理，組件全部採用鋁合金壓鑄工藝製造，鋁管連接處均採用螺釘固定，結構簡潔，可靠安全，外觀和顏色自成系列。

The series of support arm units matching 70x100mm aluminum tubes are used to hang or support medium and large control cabinets. The surface of the aluminum tubes is plastic spray, and all the support arm units are made of die-casting aluminum alloy. Each connecting part of aluminum tubes is fixed with screws. The structure is concise, stable, and safe; exterior and color are in series.



品名：箱體連接件
訂貨號：700.1.090.00
重量：1.18kg
材料：壓鑄鋁合金
可水平旋轉 0-320°

Name of product : Box connector
Order NO. : 700.1.090.00
Weight : 1.18kg
Material : die-casting aluminum alloy
0-320° rotatable horizontally

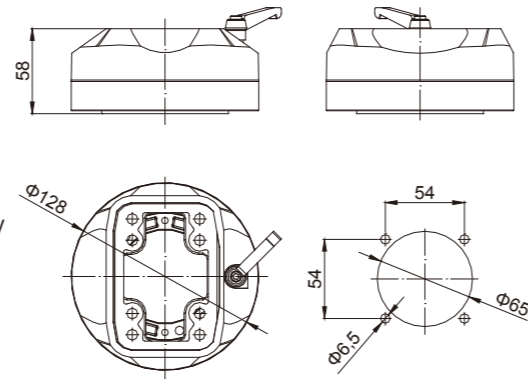
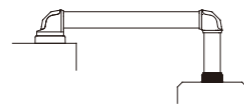

品名：90°箱體連接件
訂貨號：700.1.150.00
重量：1.86kg
材料：壓鑄鋁合金
可水平旋轉 0-320°

Name of product : 90° box connector
Order NO. : 700.1.150.00
Weight : 1.86kg
Material : die-casting aluminum alloy
0-320° rotatable horizontally

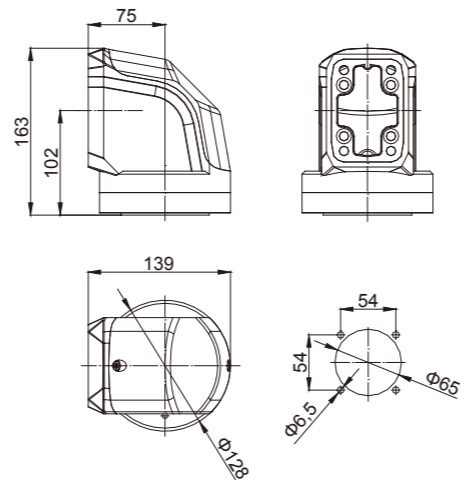
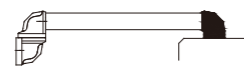

品名：90°轉角
訂貨號：700.1.100.00
重量：1.03kg
材料：壓鑄鋁合金

Name of product : 90° corner
Order NO. : 700.1.100.00
Weight : 1.03kg
Material : die-casting aluminum alloy

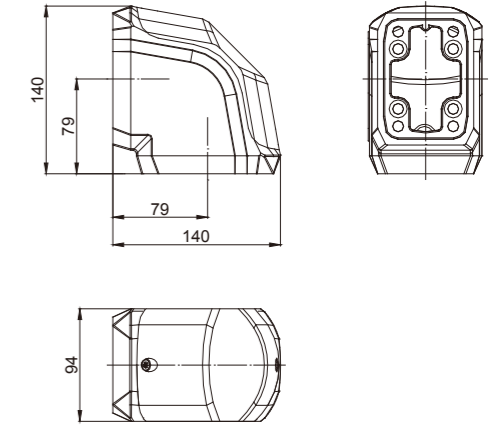
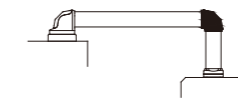

品名：頂座
訂貨號：700.1.120.00
重量：4.86kg
材料：壓鑄鋁合金
可水平旋轉 0-320°

Name of product : Footstock
Order NO. : 700.1.120.00
Weight : 4.86kg
Material : die-casting aluminum alloy
0-320° rotatable horizontally

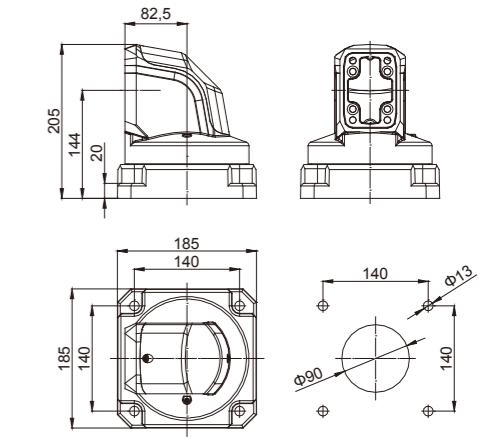

品名：水平牆座
訂貨號：700.1.110.00
重量：5.73kg
材料：壓鑄鋁合金
可水平旋轉 0-320°

Name of product : Horizontal wall support
Order NO. : 700.1.110.00
Weight : 5.73kg
Material : die-casting aluminum alloy
0-320° rotatable horizontally

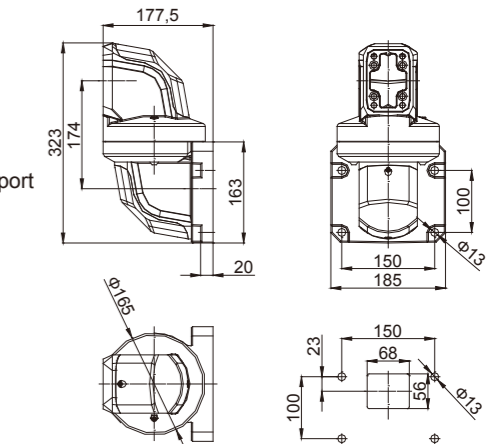
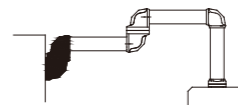

品名：中間連接件
訂貨號：700.1.130.00
重量：4.82kg
材料：壓鑄鋁合金
可水平旋轉 0-320°

Name of product : Middle connector
Order NO. : 700.1.130.00
Weight : 4.82kg
Material : die-casting aluminum alloy
0-320° rotatable horizontally

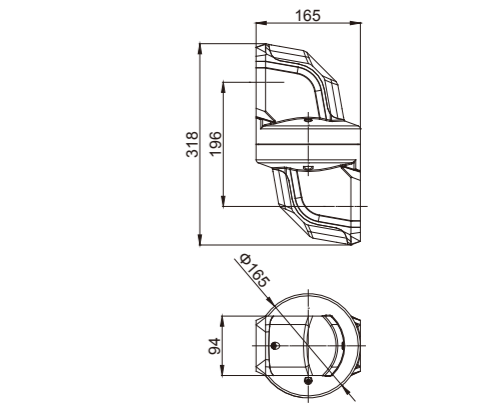
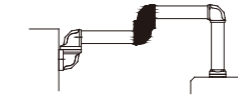



品名：垂直牆座
訂貨號：700.1.170.00
重量：5.16kg
材料：壓鑄鋁合金
可水平旋轉 0-320°

Name of product : Vertical wall support
Order NO. : 700.1.170.00
Weight : 5.16kg
Material : die-casting aluminum alloy
0-320° rotatable horizontally

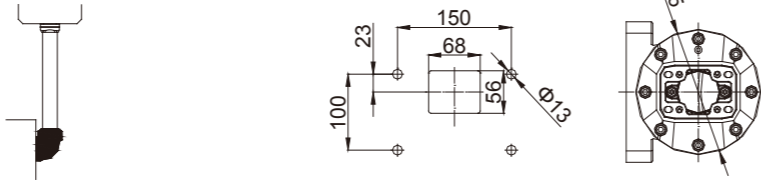

品名：固定底座
訂貨號：700.1.140.00
重量：0.63kg
材料：壓鑄鋁合金

Name of product : Fixed base
Order NO. : 700.1.140.00
Weight : 0.63kg
Material : die-casting aluminum alloy

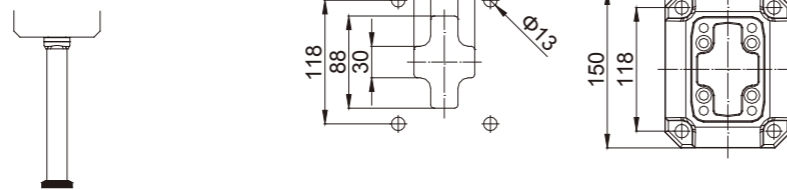

品名：可旋轉底座
訂貨號：700.1.180.00
重量：4.3kg
材料：壓鑄鋁合金
可水平旋轉0-320°

Name of product : Rotatable base
Order NO. : 700.1.180.00
Weight : 4.3kg
Material : die-casting aluminum alloy
0-320° rotatable horizontally

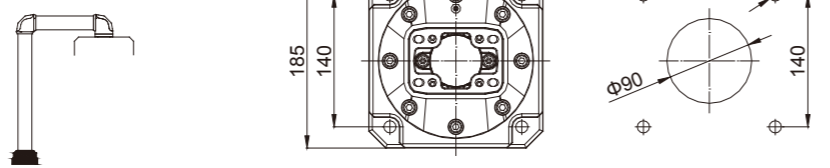

品名：可旋轉 90° 轉角
訂貨號：700.6.190.00
重量：4.27kg
材料：壓鑄鋁合金
可水平旋轉 0-320°

Name of product : Rotatable 90° corner
Order NO. : 700.6.190.00
Weight : 4.27kg
Material : die-casting aluminum alloy
0-320° rotatable horizontally

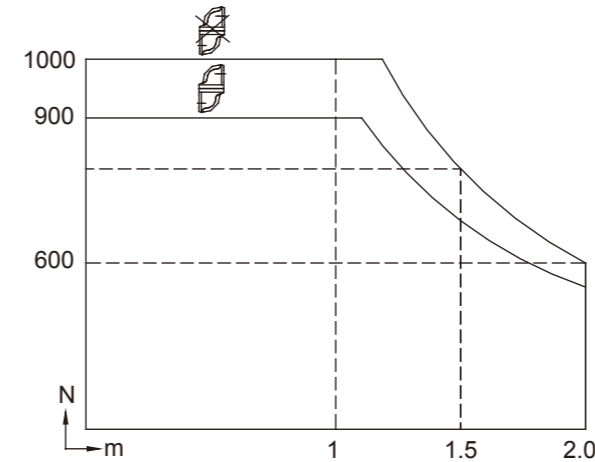

70100鋁管規格表(配70100懸臂) :
Size table of 70100 aluminum tubes
(for 70100 support arms)

鋁管長度Length	訂貨號Order NO.
0.25 m	700.1.025.70
0.5 m	700.1.050.70
1 m	700.1.100.70
1.5 m	700.1.150.70
2 m	700.1.200.70



70100鋁管
70100 Aluminum tube

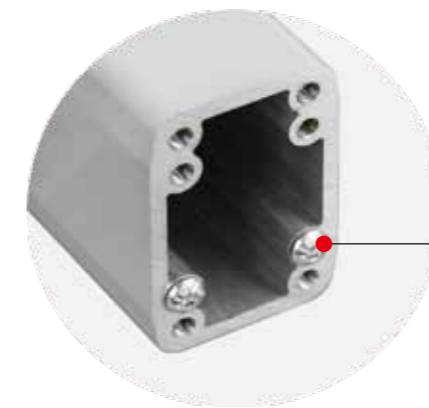
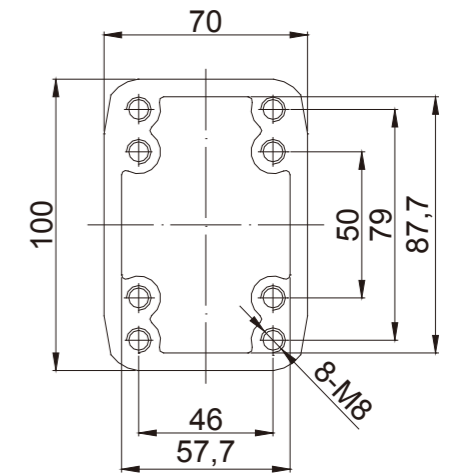

調節螺釘
Adjusting screw

70100水平鋁管安裝方法：
在把鋁管連接到懸臂接頭之前，先把2個圓頭調節螺釘旋緊在鋁管兩端面上（如圖位置）。

Installation method for 70100 horizontal aluminum tube:
Tighten 2 round-head adjusting screws onto the end face of the aluminum tube before connecting the tube to the joints of the support arm.(see the picture)

按如圖所示，同時調節2個圓頭螺釘，根據整個懸臂系統承重不同旋出一定距離（1~5mm），使水平段連接管上抬一定角度。

Adjust these 2 round-head screws as the picture, and then rotate a certain distance (1~5mm) according to the individual loading of the support arm, lifting the horizontal tube up to a certain angle.

調節連接管水平度
Adjusting levelness of the connecting tube

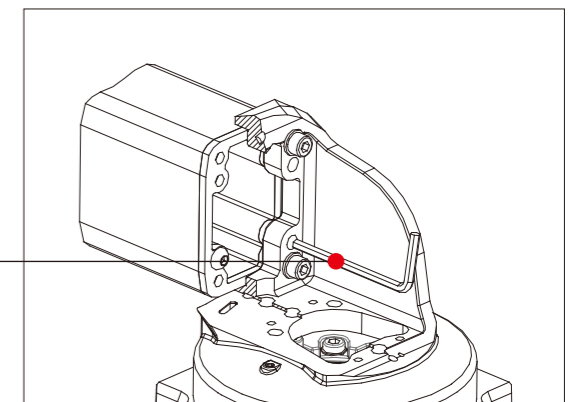

80 系列 重型懸臂組件
80 Series Heavy Support Arm Units



該系列經濟型懸臂組件配合80x80mm鋼管用於懸掛或支撐控制箱體。設計中充分考慮了各個組件的材料和結構的合理性，提升了各個組件的剛性，從而保證了整個懸臂或支撐系統的強度。

The economical series of support arm units matching 80x80mm steel tubes are used to hang or support medium and large control cabinets. The design is totally in regard of the reasonability of the material of each unit and the structure, raising firmness and assuring strength of the support arm system.



品名：箱體連接件
訂貨號：800.8.090.00
重量：2.5kg
材料：壓鑄鋁合金
可水平旋轉 0-320°

Name of product : Box connector
Order NO. : 800.8.090.00
Weight : 2.5kg
Material : die-casting aluminum alloy
0-320° rotatable horizontally

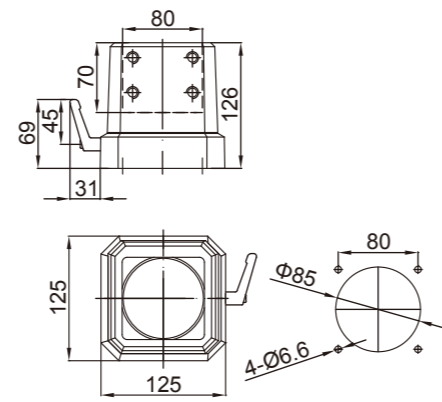
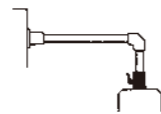

品名：90°轉角
訂貨號：800.8.100.00
重量：3.5kg
材料：壓鑄鋁合金

品名：90°重型轉角
訂貨號：800.8.100.01
重量：7.2kg
材料：鑄鋼

Name of product : 90° corner
Order NO. : 800.8.100.00
Weight : 3.5kg
Material : die-casting aluminum alloy

Name of product : 90° heavy corner
Order NO. : 800.8.100.01
Weight : 7.2kg
Material : cast steel

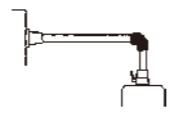
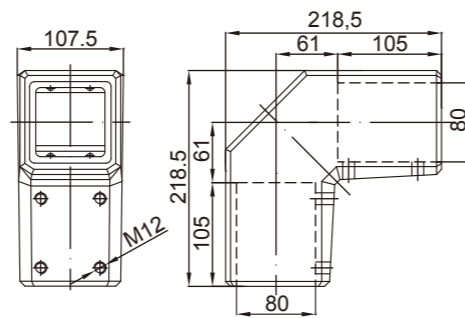

(普通 Normal)

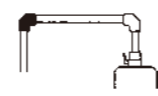

(重型 Heavy)

80 系列 重型懸臂組件
80 Series Heavy Support Arm Units



品名：頂座
訂貨號：800.8.120.00
重量：17kg
材料：鑄鋼
可水平旋轉 0-320°

Name of product : Footstock
Order NO. : 800.8.120.00
Weight : 17kg
Material : cast steel
0-320° rotatable horizontally

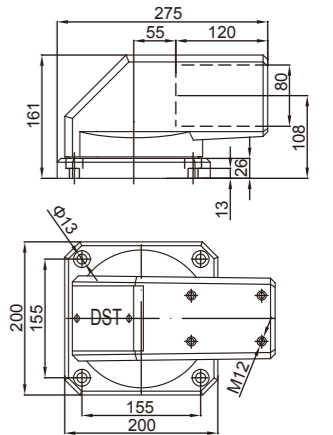

品名：底座
訂貨號：800.8.140.00
重量：12kg
材料：鑄鋼
不可旋轉

Name of product : Base
Order NO. : 800.8.140.00
Weight : 12kg
Material : cast steel
not rotatable

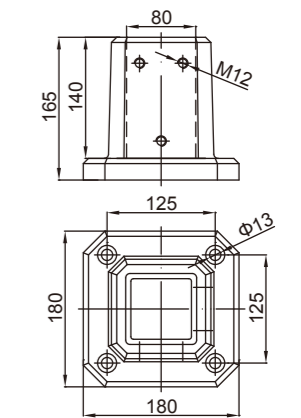
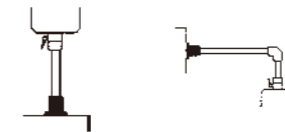

品名：牆座
訂貨號(A型)：800.8.110.00
訂貨號(B型)：800.8.110.01
重量：15kg
材料：鑄鋼
可水平旋轉 0-180°

Name of product : Wall support
Order NO. (Type A) : 800.8.110.00
Order NO. (Type B) : 800.8.110.01
Weight : 15kg
Material : cast steel
0-180° rotatable horizontally

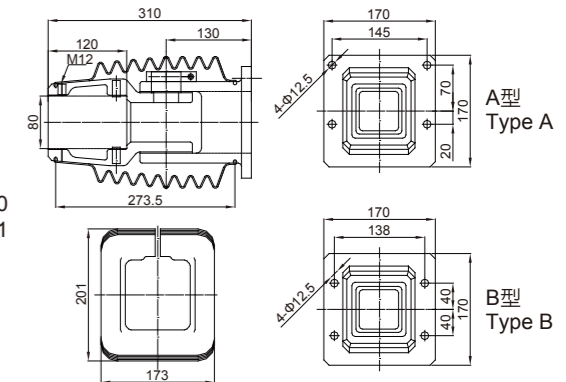

品名：中間連接件
訂貨號：800.8.130.00
重量：15kg
材料：鑄鋼
可水平旋轉 0-180°

Name of product : Middle connector
Order NO. : 800.8.130.00
Weight : 15kg
Material : cast steel
0-180° rotatable horizontally

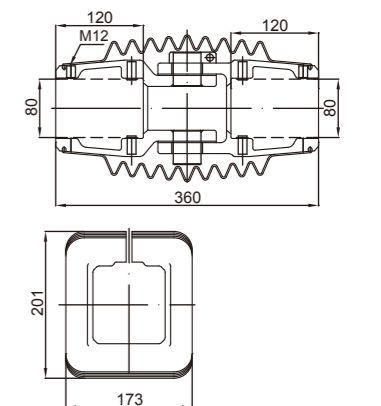
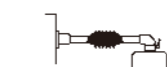

80 系列 重型懸臂組件

80 Series Heavy Support Arm Units



品名：90° 箱體連接件
 訂貨號：800.8.150.00
 重量：2.5kg
 材料：壓鑄鋁合金
 可水平旋轉 0-320°

Name of product : 90° box connector
 Order NO. : 800.8.150.00
 Weight : 2.5kg
 Material : die-casting aluminum alloy
 0-320° rotatable horizontally

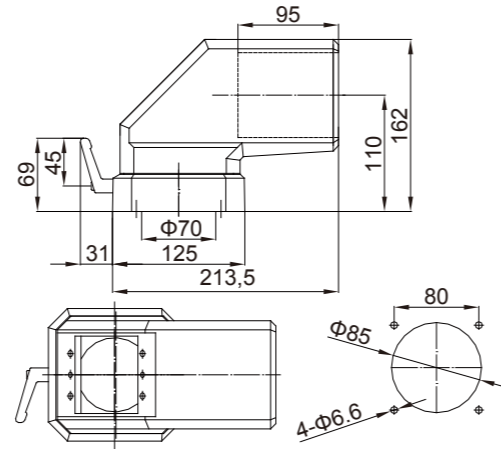
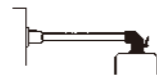

品名：防顫箱座
 訂貨號：800.8.080.00
 重量：2.56kg
 材料：壓鑄鋁合金

Name of product :
 Anti-vibration box base
 Order NO. : 800.8.080.00
 Weight : 2.56kg
 Material :
 die-casting aluminum alloy

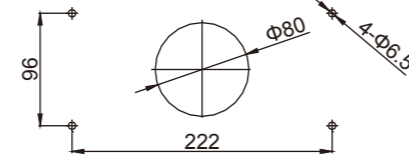
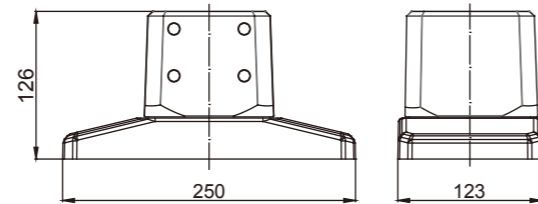
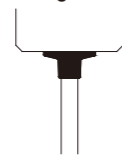

品名：90度防顫箱座
 訂貨號：800.8.085.00
 重量：2.87kg
 材料：壓鑄鋁合金

Name of product :
 90° Anti-vibration box base
 Order NO. : 800.8.085.00
 Weight : 2.87kg
 Material :
 die-casting aluminum alloy

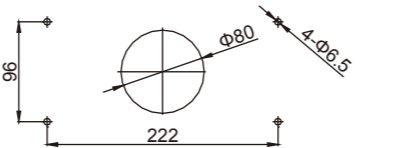
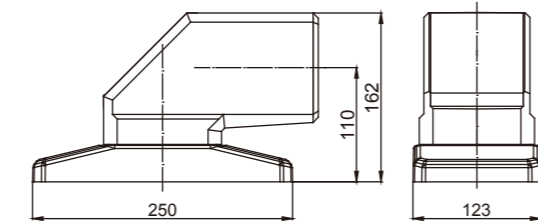

品名：15° 斜面連接件
 訂貨號：800.8.160.00
 重量：0.45kg
 材料：壓鑄鋁合金

Name of product : 15° tilting connector
 Order NO. : 800.8.160.00
 Weight : 0.45kg
 Material : die-casting aluminum alloy

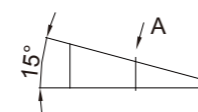
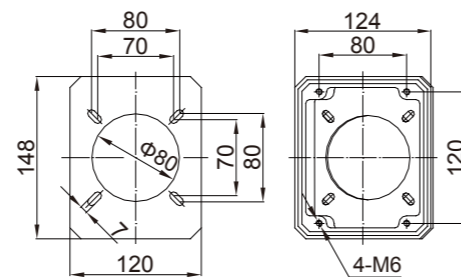
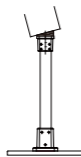

80 系列 重型懸臂組件

80 Series Heavy Support Arm Units



鋼管 (表面噴塑)
 Steel tube (diecasted aluminium alloy shell)



鋁管 (陽極氧化)
 Aluminum tube (anodized)

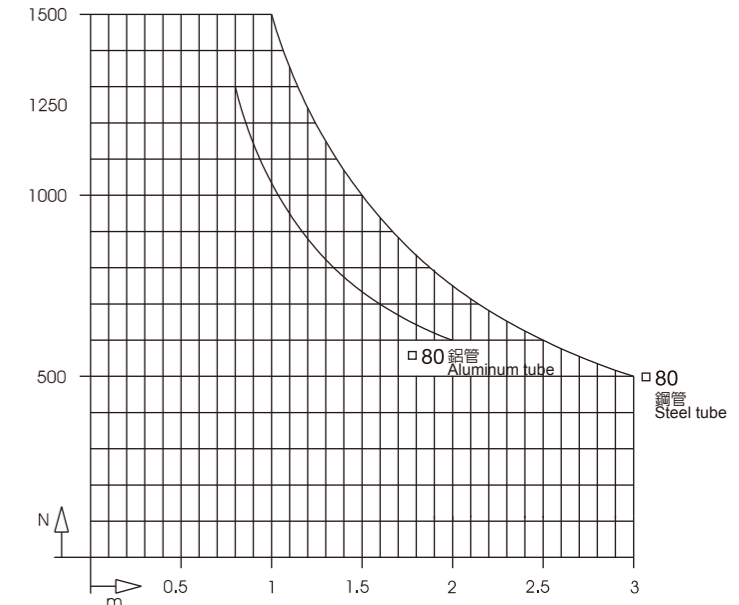

80系列重型懸臂承重力圖
 Load - bearing chart of 80 series heavy support arm

80方管規格表(配80重型懸臂):
 Size table of 80 square tubes (for 80 heavy support arms)

方管長度 Length of square tube	鋼管訂貨號 Steel tube order NO.	鋁管訂貨號 Aluminum tube order NO.
0.5 m	800.8.050.80	800.9.050.80
1 m	800.8.100.80	800.9.100.80
1.5 m	800.8.150.80	800.9.150.80
2 m	800.8.200.80	800.9.200.80
2.5 m	800.8.250.80	
3 m	800.8.300.80	

← 立柱

立柱，是為標準懸臂組件無法實現的結構而定製的輔助支撐配件，全部採用鋼管和鋼板通過焊接而成，灰白色外表噴塑與懸臂組件混為一體。
 根據不同的設計要求，立柱方形鋼管有80、100mm規格，以符合整體美觀效果。上下連接法蘭視不同的對接懸臂組件和安裝方式而定製。

← Pillar

The pillar is a supplementary support part for the structure of the support arm units. All welded of steel tubes and steel sheets, the gray white diecasted aluminum alloy shell appears as an ensemble with the support arm units. The square steel tubes have two specs of 80 and 100mm, meeting different design requirements and aesthetic effects.

立柱訂貨號： Pillar order NO. :
 900.9.XXXX.08 80 方立柱 900.9.XXXX.08 80 square pillar
 900.9.XXXX.10 100方立柱 900.9.XXXX.10 100 square pillar

舉例：1.5m 80方立柱 900.9.1500.08
 0.75m 100方立柱 900.9.0750.10

Example : 1.5m 80 square pillar 900.9.1500.08
 0.75m 100 square pillar 900.9.0750.10

DA 系列 鑄鋁接線盒

DA Series Aluminum Casting Terminal Box

DA系列鑄鋁接線盒採用高質量壓鑄鋁合金材料壓鑄而成。具有結構合理簡潔、優秀的抗衝擊性能、有效的密封性能和良好的抗電磁干擾的特點。

接線盒內可安裝接線端子、線路板或其他電氣元件，適用於各種工業自動化領域。

DA series aluminum casting terminal box is diecast of high-quality aluminum casting alloy. It possesses features of reasonable and concise structure, excellent impact resistance, effective sealability, and splendid anti-EMI (Electromagnetic Immunity).

The terminal box could install connecting terminals, PCBs (Printed Circuit Boards), or other electrical elements inside and apply to all fields of industrial automation.

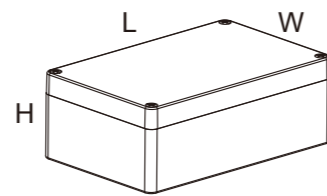

規格表 Size table

單位Unit : mm

型號 Model	長(L) (Length)	寬(W) (Width)	高(H) (Height)	卡軌長度(H) (Length of the guide rail)
DA111	64	58	36	---
DA121	98	64	36	---
DA131	125	80	57	115 (TS15)
DA132	125	80	80	115 (TS15)
DA141	75	80	57	64 (TS15)
DA142	75	80	80	64 (TS15)
DA161	175	80	57	165 (TS15)
DA162	175	80	80	165 (TS15)
DA171	250	80	57	240 (TS15)
DA172	250	80	80	240 (TS15)
DA211	122	120	80	109 (TS35)
DA221	160	160	90	147 (TS35)
DA231	220	140	80	207 (TS35)
DA241	220	120	90	207 (TS35)
DA251	200	230	110	185 (TS35)
DA261	260	160	90	245 (TS35)
DA271	320	160	90	306 (TS35)
DA281	280	230	110	265 (TS35)
DA331	330	230	110	315 (TS35)
DA401	402.5	310	110	385 (TS35)
DA411	400	230	110	382 (TS35)
DA421	402.5	310	140	385 (TS35)

技術參數：
 材料：壓鑄鋁合金AlSi12
 密封條：矽橡膠（可提供特種密封條）
 防護等級：IP66(可提供認證)
 使用環境溫度：-50°C至+130°C
 盒蓋螺釘：不銹鋼十字槽（不易脫落）
 顏色：銀灰，近似RAL7001
 （可提供特殊色）

Technical parameters：
 Material：ALSi12 die-cast aluminum alloy
 Rubber Seal strip：Silicone rubber
 (special type available)
 Protection Rating：
 IP66(providing Certificates)
 Environment temperature：
 -50°C to +130°C
 Cover screws：
 Stainless steel cross slot
 (not easy to fall off)
 Color：silver gray akin to RAL7001
 (special color available)

Ex 增安型防爆接線盒：
 該系列除了DA111和DA4**，均可提供增安型防爆接線盒。

Explosion-proof terminal box with strengthened safety:
 The series except DA111 and DA4** all provide explosion-proof terminal box with strengthened safety.

DA 系列 鑄鋁接線盒

DA Series Aluminum Casting Terminal Box

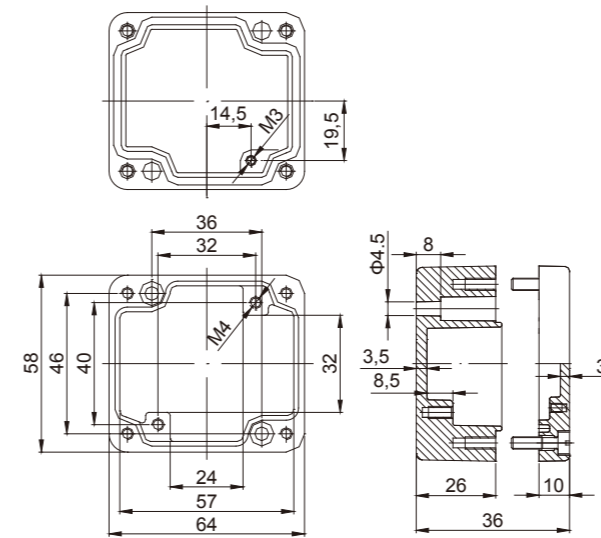

型號：DA111 重量：0.16kg
 規格：58x64x36mm

Model：DA111 Weight：0.16kg
 Size：58x64x36mm

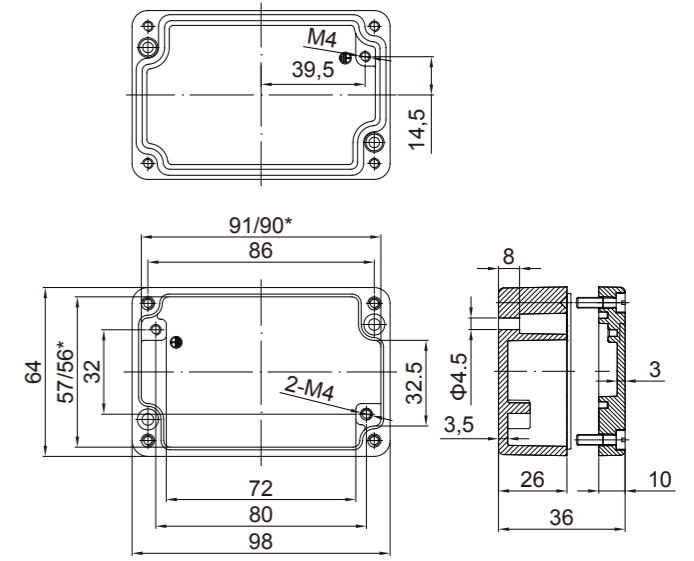

型號：DA121 重量：0.23kg
 規格：64x98x36mm

Model：DA121 Weight：0.23kg
 Size：64x98x36mm

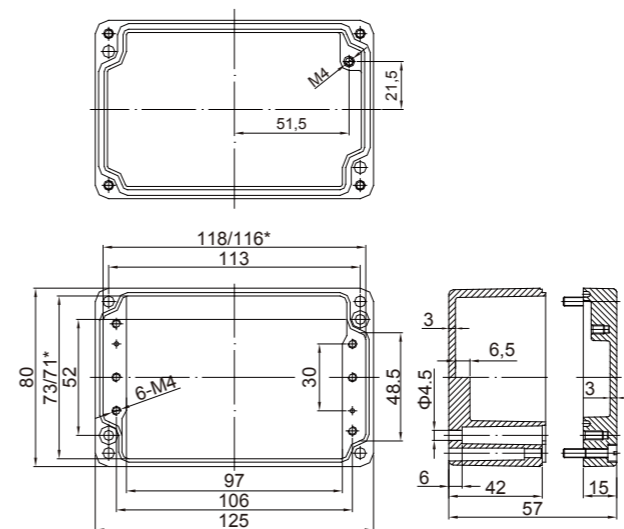

型號：DA131 重量：0.39kg
 規格：80x125x57mm
 卡軌型號和長度：TS15 -115mm

Model：DA131 Weight：0.39kg
 Size：80x125x57mm
 Model and length of the guide rail：TS15 -115mm

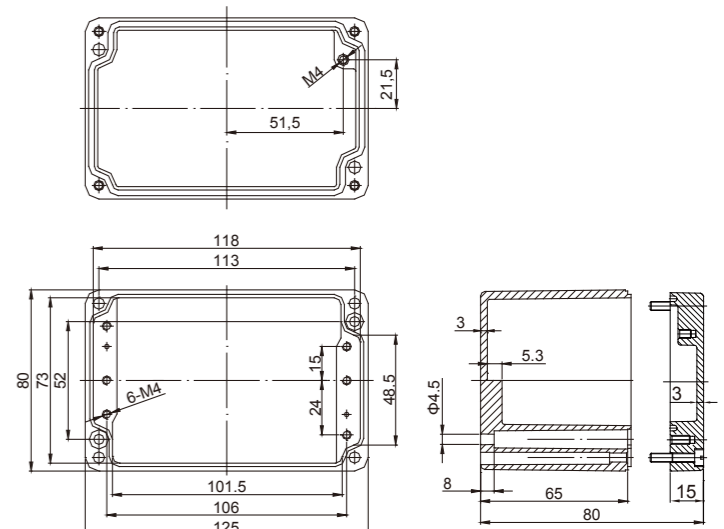

型號：DA132 重量：0.43kg
 規格：80x125x80mm
 卡軌型號和長度：TS15 -115mm

Model：DA132 Weight：0.43kg
 Size：80x125x80mm
 Model and length of the guide rail：TS15 -115mm

DA 系列 鑄鋁接線盒

DA Series Aluminum Casting Terminal Box

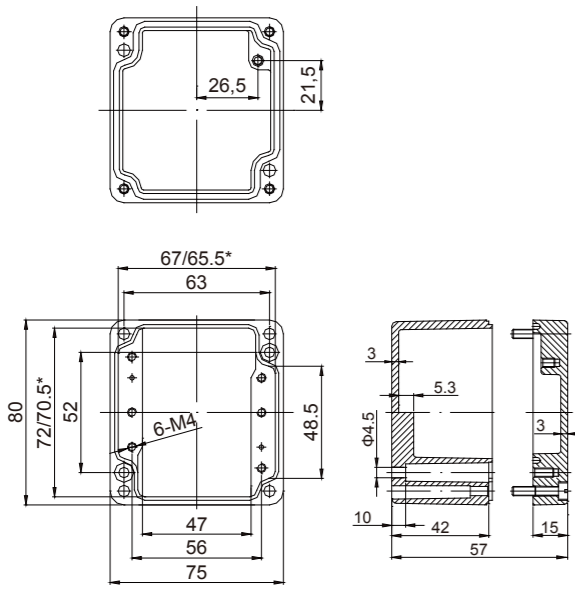

型號：DA141 重量：0.28kg
規格：80x75x57mm
卡軌型號和長度：TS15 -64mm

Model : DA141 Weight : 0.28kg
Size : 80x75x57mm
Model and length of the guide rail : TS15 -64mm

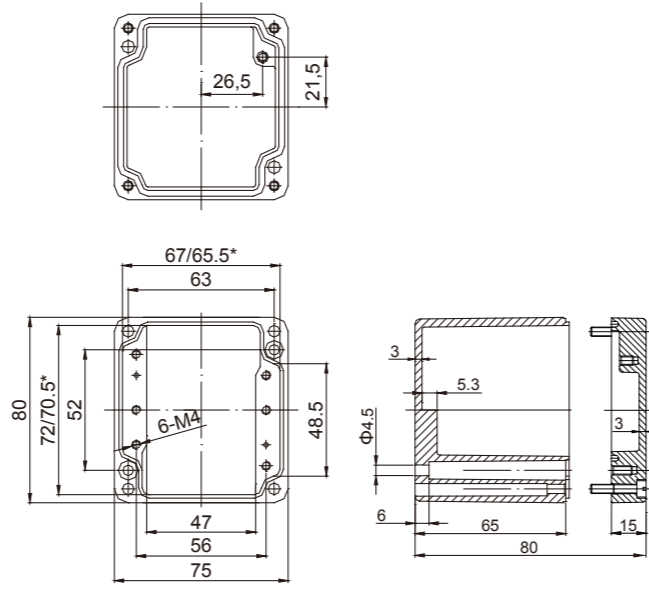

型號：DA142 重量：0.35kg
規格：80x75x80mm
卡軌型號和長度：TS15 -64mm

Model : DA142 Weight : 0.35kg
Size : 80x75x80mm
Model and length of the guide rail : TS15 -64mm

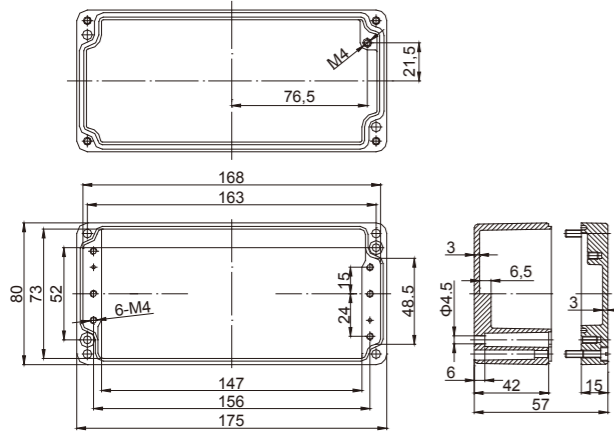

型號：DA161 重量：0.55kg
規格：80x175x57mm
卡軌型號和長度：TS15 -165mm

Model : DA161 Weight : 0.55kg
Size : 80x175x57mm
Model and length of the guide rail : TS15 -165mm

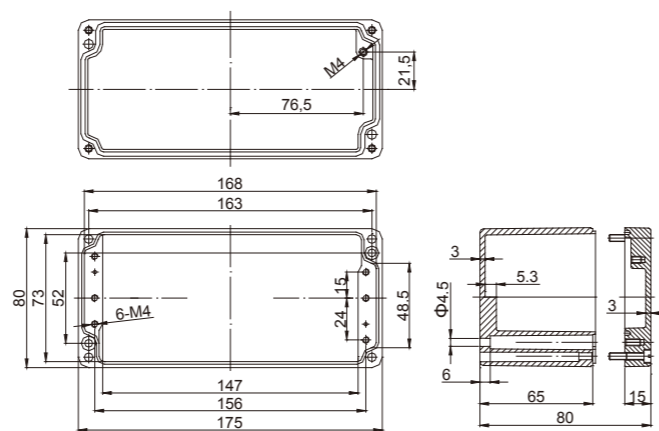

型號：DA162 重量：0.67kg
規格：80x175x80mm
卡軌型號和長度：TS15 -165mm

Model : DA162 Weight : 0.67kg
Size : 80x175x80mm
Model and length of the guide rail : TS15 -165mm

DA 系列 鑄鋁接線盒

DA Series Aluminum Casting Terminal Box

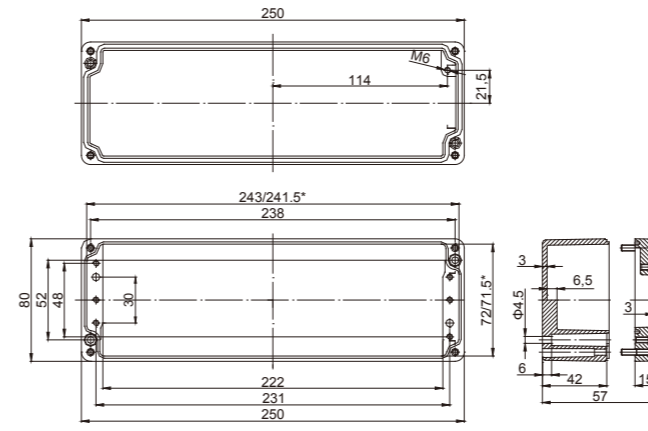

型號：DA171 重量：0.8kg
規格：80x250x57mm
卡軌型號和長度：TS15 -240mm

Model : DA171 Weight : 0.8kg
Size : 80x250x57mm
Model and length of the guide rail : TS15 -240mm

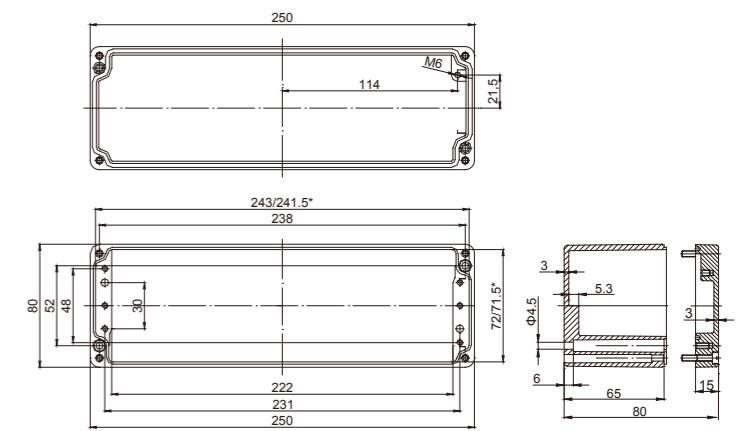

型號：DA172 重量：0.95kg
規格：80x250x80mm
卡軌型號和長度：TS15 -240mm

Model : DA172 Weight : 0.95kg
Size : 80x250x80mm
Model and length of the guide rail : TS15 -240mm

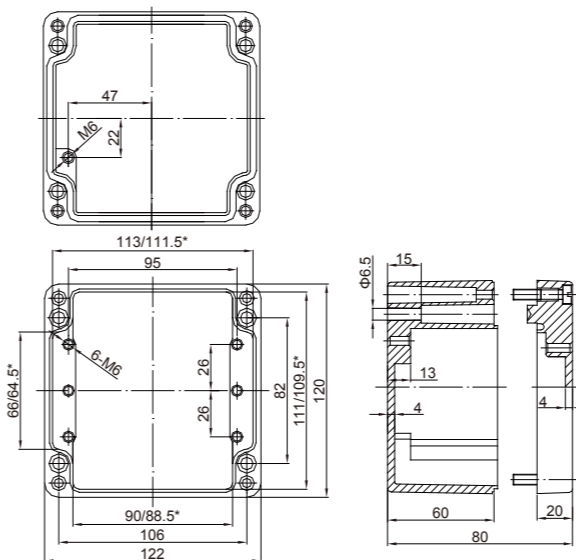

型號：DA211 重量：0.8kg
規格：120x122x80mm
卡軌型號和長度：TS35 -109mm

Model : DA211 Weight : 0.8kg
Size : 120x122x80mm
Model and length of the guide rail : TS35 -109mm

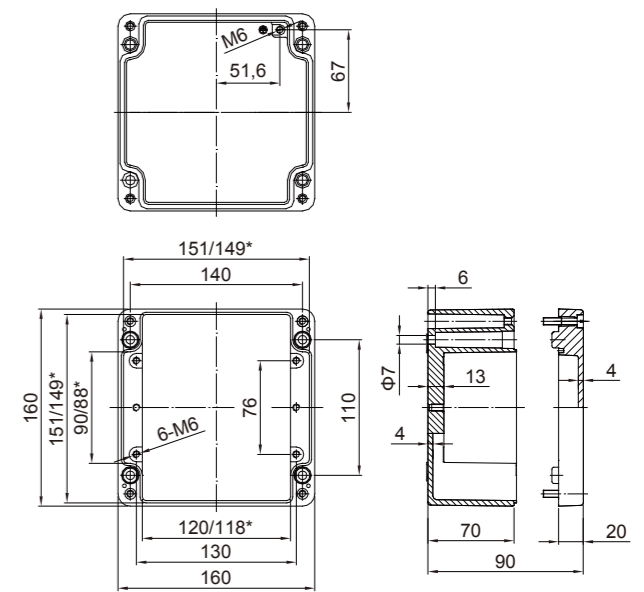

型號：DA221 重量：1.5kg
規格：160x160x90mm
卡軌型號和長度：TS35 -147mm

Model : DA221 Weight : 1.5kg
Size : 160x160x90mm
Model and length of the guide rail : TS35 -147mm

DA 系列 鑄鋁接線盒

DA Series Aluminum Casting Terminal Box

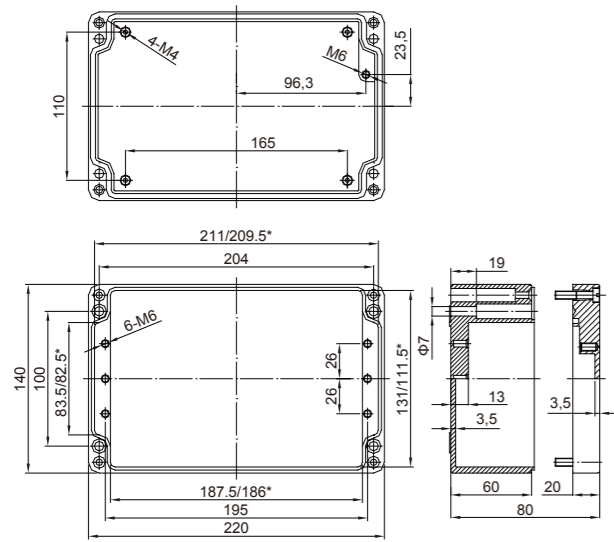

型號：DA231 重量：1.4kg
規格：140x220x80mm
卡軌型號和長度：TS35 -207mm

Model : DA231 Weight : 1.4kg
Size : 140x220x80mm
Model and length of the guide rail : TS35 -207mm

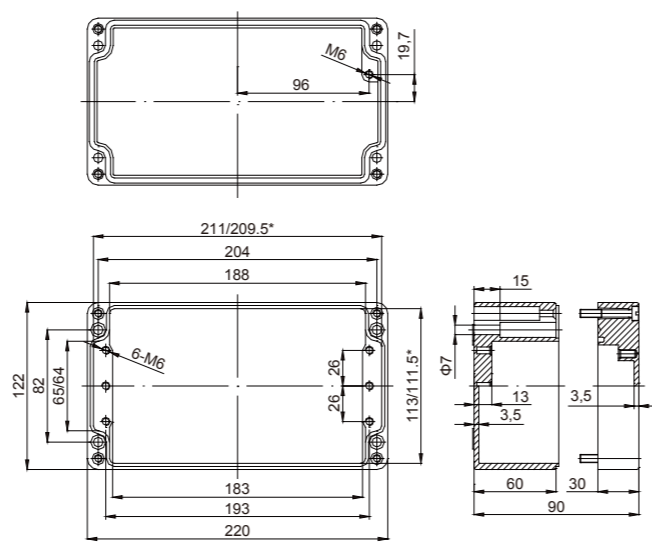

型號：DA241 重量：1.4kg
規格：120x220x90mm
卡軌型號和長度：TS35 -207mm

Model : DA241 Weight : 1.4kg
Size : 120x220x90mm
Model and length of the guide rail : TS35 -207mm

DA 系列 鑄鋁接線盒

DA Series Aluminum Casting Terminal Box

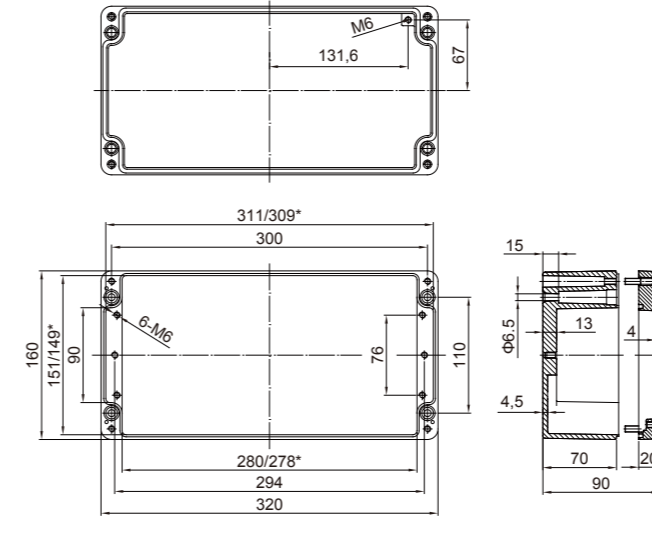

型號：DA271 重量：2.6kg
規格：160x320x90mm
卡軌型號和長度：TS35 -306mm

Model : DA271 Weight : 2.6kg
Size : 160x320x90mm
Model and length of the guide rail : TS35 -306mm

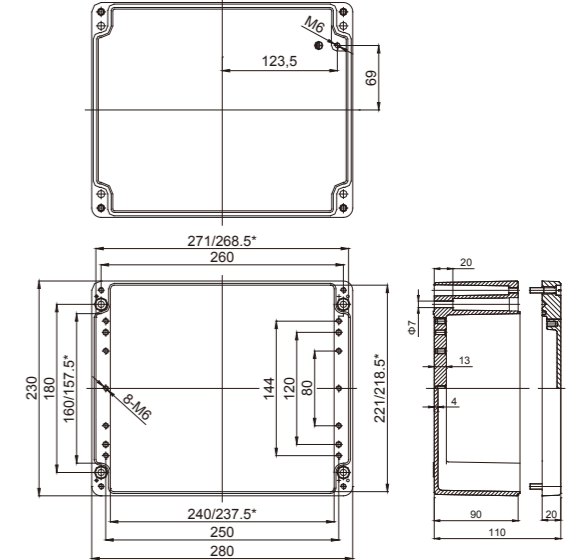

型號：DA281 重量：3.0kg
規格：230x280x110mm
卡軌型號和長度：TS35 -265mm

Model : DA281 Weight : 3.0kg
Size : 230x280x110mm
Model and length of the guide rail : TS35 -265mm

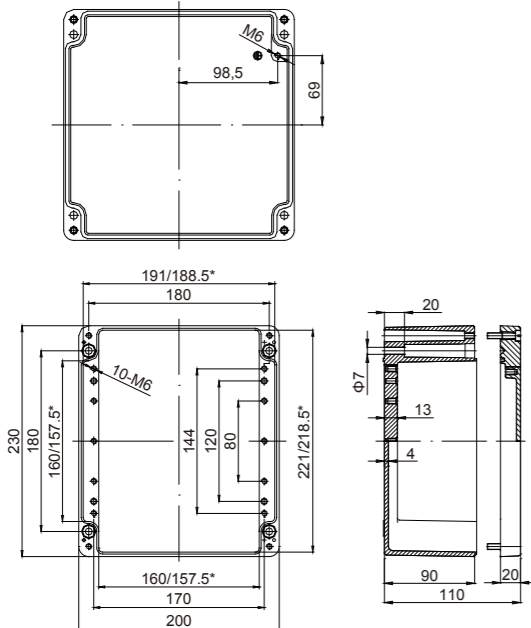

型號：DA251 重量：2.7kg
規格：200x230x110mm
卡軌型號和長度：TS35 -185mm

Model : DA251 Weight : 2.7kg
Size : 200x230x110mm
Model and length of the guide rail : TS35 -185mm

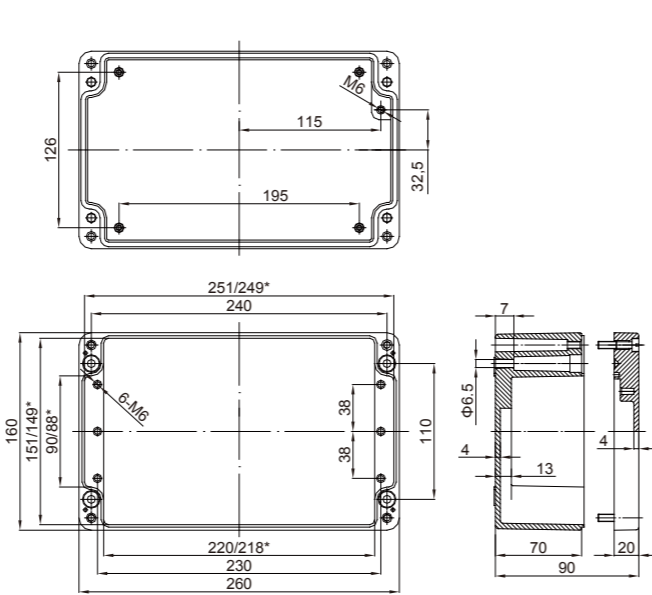

型號：DA261 重量：2.1kg
規格：160x260x90mm
卡軌型號和長度：TS35 -245mm

Model : DA261 Weight : 2.1kg
Size : 160x260x90mm
Model and length of the guide rail : TS35 -245mm

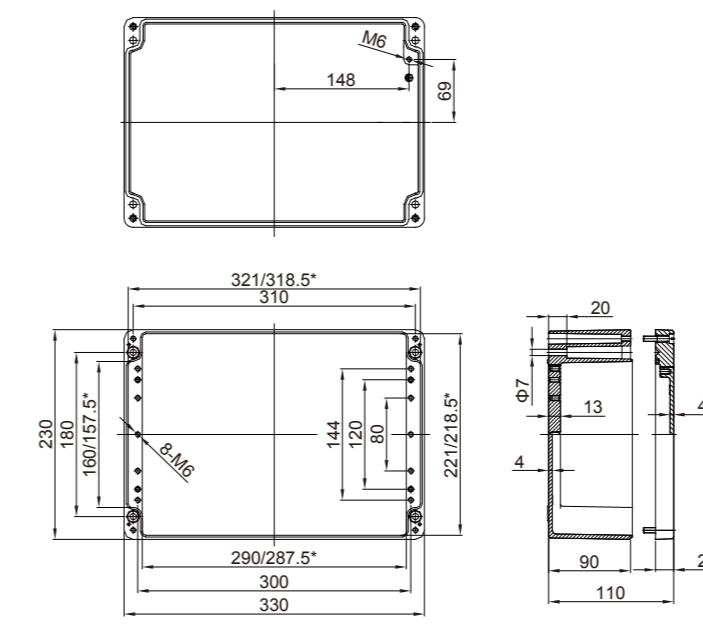

型號：DA331 重量：3.4kg
規格：230x330x110mm
卡軌型號和長度：TS35 -315mm

Model : DA331 Weight : 3.4kg
Size : 230x330x110mm
Model and length of the guide rail : TS35 -315mm

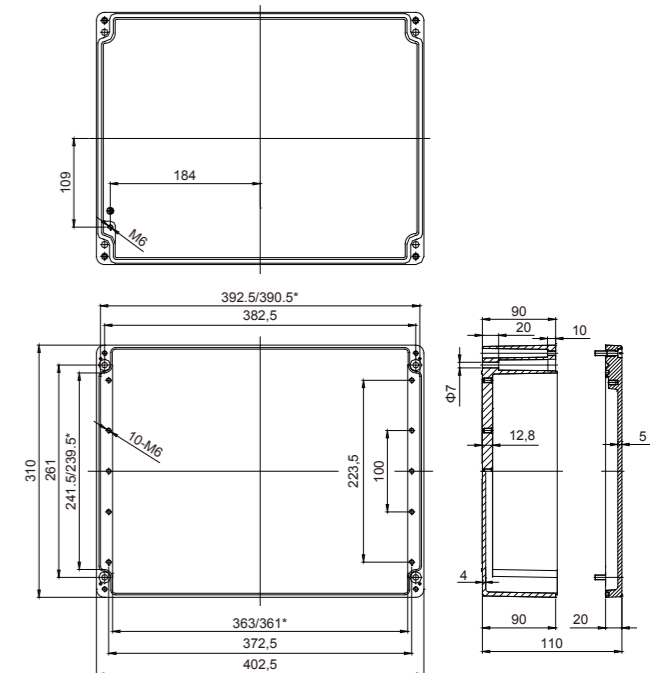

型號：DA401 重量：5.8kg
規格：310x402.5x110mm
卡軌型號和長度：TS35 -385mm

Model : DA401 Weight : 5.8kg
Size : 310x402.5x110mm
Model and length of the guide rail : TS35 -385mm

DA 系列 鑄鋁接線盒

DA Series Aluminum Casting Terminal Box

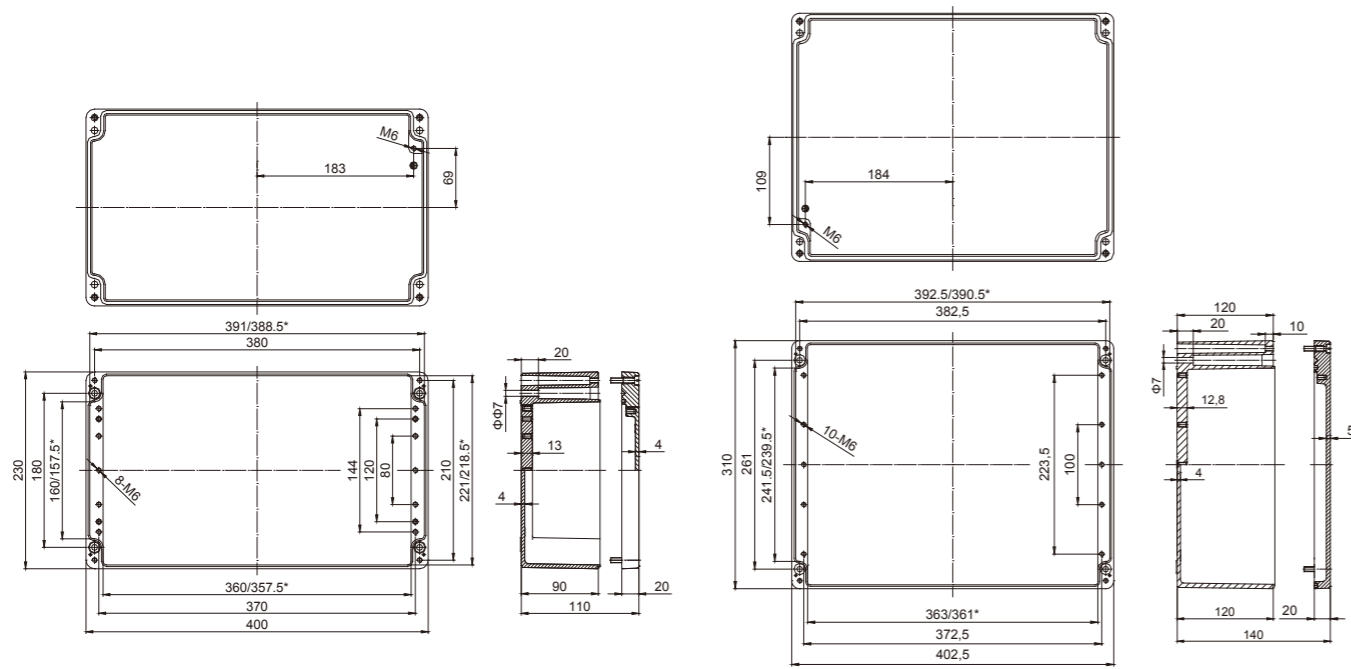

型號：DA411 重量：4.3kg
規格：230x400x110mm
卡軌型號和長度：TS35 -382mm

Model : DA411 Weight : 4.3kg
Size : 230x400x110mm
Model and length of the guide rail : TS35 -382mm

型號：DA421 重量：5.9kg
規格：310x402.5x140mm
卡軌型號和長度：TS35 -385mm

Model : DA421 Weight : 5.9kg
Size : 310x402.5x140mm
Model and length of the guide rail : TS35 -385mm



CG系列 公制電纜接頭

CG series Metric cable bond

技術參數：

材料：PA6(尼龍)

密封圈：丁腈橡膠

防護等級：IP66

使用環境溫度：-25°C~+100°C

顏色：灰白：PAL7001 黑色：PAL9005

Technical parameters :

Material : PA6(Nylon)

Gasket : Butyronitrile rubber

Protection Rating : IP66

Environment temperature : -25°C~+100°C

Color : Gray white: PAL7001 Black: PAL9005

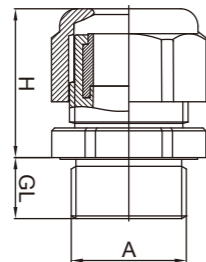

規格表 Specifications :

規格 Model	型號 Model number	對應PG制 Correspondence of the PG system	電纜鎖緊範圍 Tightening range of the electric cable (mm)	GL (mm)	H (mm)		A	螺母型號 Screw model
M12-1	CG1211	PG7	3-6.5	8	20	15	M12x1.5	CW12
M16-1	CG1611	PG9	4-8	9	22	19	M16x1.5	CW16
M16-3	CG1631	PG11	5-10	9	24	22	M16x1.5	CW16
M20-1	CG2011	PG13.5	6-12	10	27	24	M20x1.5	CW20
M20-3	CG2031	PG16	10-14	11	28	27	M20x1.5	CW20
M25-1	CG2511	PG21	13-18	11	30	33	M25x1.5	CW25



IP55 PS九折型材KD組合櫃 / 不鏽鋼 / 金屬電控箱
 PS-KD Modular Enclosure / Stainless Electronic Cabinet / Metal Electronic Cabinet

IP66 AE系列電控箱 / 變頻器控制箱 / PLC盤
 AE Series of Electronic Cabinet / Inverter Control Cabinet / PLC Panel

Waterproof & Dustproof

防水&防塵 最堅實的保護



使用PS九折KD型材之優勢： Advantages of PS-KD(Knock-Down) Section Bar

■ 特徵：

- PS九折型材應用，KD防呆快速組拆。
- 焊接、噴塗、物流，省工省時降半成本。
- 箱體承受2000kg載重不變型，結構更勝同型強度。
- 無限拼盤延伸，防呆快速連結，並可適度調整水平。
- 運用叉、拖板車可任意快速移動，省時省工又方便。
- 符合PS規格尺寸，五金零組件相容共通使用。

Features：

- Application of PS series of section bar, and KD(Knock-Down) fool-proof joints enhancing quick assembly/ disassembly.
- Cost reduction of 50% of welding, painting, and distribution
- Loading up to 2000kg without deformation, the structure stronger than any other similar products.
- Unlimited combination of PS-KD modular enclosures with fool-proof fast assembly and horizontal adjustment
- Easily, directly, and quickly transported by forklift, time-saving, money-saving, and convenient.
- In accordance with specs of PS series and compatibility of PS's kits and parts

■ 以遠處一案500套為例：2000(H)cm x 800(W)cm x 600(D)cm



■ 一般整套物流

500套共需**24**個20呎貨櫃 =  **x 24**

■ KD拆卸式型材

500套共需**11**個20呎貨櫃 =  **KD 型材 x 1** +  **門側板 x 10**

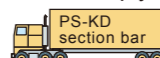
Example of logistics：500 sets (2000(H)cm x 800(W)cm x 600(D)cm) in a distance

- General transportation for a 500-set package needs 24 20'FT shipping containers--  **x 24**
- Transportation for a 500-set package of PS-KD knock-down section bar simply needs 11 20'FT shipping containers—
 1 container of PS-KD section bar + 10 containers of door panels  **PS-KD section bar x 1** +  **Door panels x 10**

■ KD九折PS型材組裝，只需3分鐘，鎖緊8個M10防呆45°螺絲完成後孔距規格完全符合目前市購之孔距尺寸，也可以只購原KD型材。

Single PS-KD section bar available. Pitches of PS-KD section bar accord with all those on the market, and It simply takes 3 minutes to assemble the PS-KD section bar, by tightening 8 M10 fool-proof 45° screws.



單門組合箱

Single-gated Modular Enclosure



雙門組合箱

Double-gated Modular Enclosure



19"電腦機櫃

19" Server Rack

KD組合式型材

PS-KD Modular Section Bar

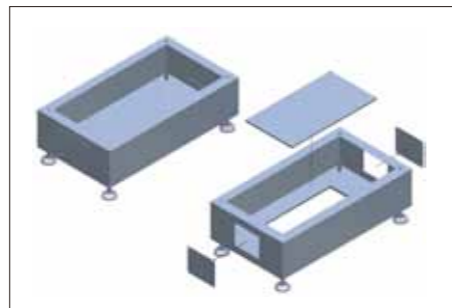
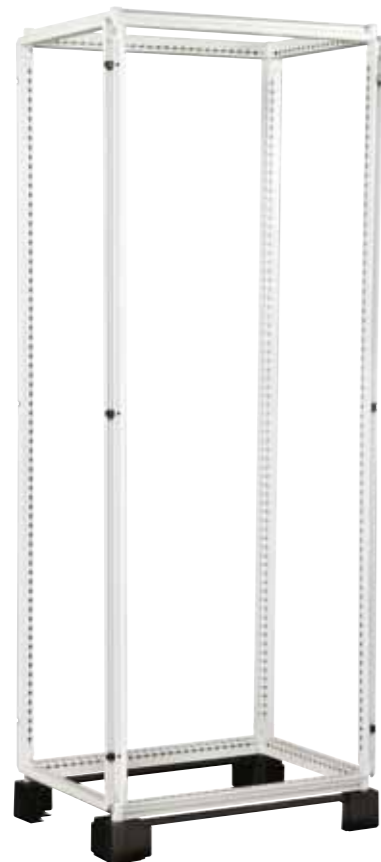

■不鏽鋼底座 Stainless base set



■強力磁吸式T5日光燈，可任意移動、強力附著、節省安裝、固定時間人力，照亮您想亮的地方。
(專利產品M324165)
Powerful magnetic T5 fluorescent lamp, moveable, strongly magnetic, saving installation cost, and lightening any place at will (patent No. M324165)



■強力磁吸式T5日光燈
可以任意移動，強力附著、節省安裝時間及人力，照亮您想照亮的地方。
Powerful magnetic T5 fluorescent lamp, moveable, strongly magnetic, saving installation cost, and lightening any place at will



■安裝底板滑組
安裝後之底板，上箱定位。往後滑動至後端，再往上推行至定點，即可固定螺絲，輕易完成安裝。
Bottom Plate with slide guide
User-friendly slide guide makes assembly/disassembly easier, faster and safer



■拆卸式底座
1.每個獨立腳座皆可承受1800kg以上，絕不變形。
2.每個腳座皆有調整水平高低，並從外側固定於地面之功能。
3.塑膠護蓋，美觀大方。
4.高度為100mm，可堆疊，視需求增加高度。
Patent independent adjustable base set
1.Each single corner base with load capacity of 1800kg without distortion
2.Adjustable outwards in accordance with actual horizontal level
3.Pretty plastic protecting cover
4.100mm height for each base set, able to be piled if needed



■雙門上下特殊防水密封設計、通過IP55測試
IP55 double doors with sealed water-resistant design



■鎖緊後框正、防呆，堅固不變形
Patent PS-KD fool-proof corner joint assuring upright and strong structure



■箱體底座特殊設計，不需要棧板，叉車即可輕易移動。
Patent design of base set, easily, directly, and quickly transported by forklift



■KD拆卸式型材
組裝迅速、結構超強，節省運輸成本及空間。
KD (knock-down) section bar
Quick assembling, strong structure, reduction of space and transporting cost



■箱體前後保護桿設計
以利拖板車任意移動、載重不變形。
Front and rear protecting rod, assuring cabinet carried at will by forklift without distortion



■客製化拼盤箱體
組裝迅速、結構超強，節省運輸成本、空間
Customized combination of enclosures
Design for quick enclosure combinationsaves time and labor.

AE系列控制箱
AE Series of Electronic Cabinet

IP55 IP66



NO.	型號 item No.	箱體尺寸 (HxWxD) m/m	型式 Type
1	CY302015	300 x 200 x 150	直 (Straight)
2	CY303018	300 x 300 x 180	直 (Straight)
3	CY403018	400 x 300 x 180	直、橫 (Straight/Horizontal)
4	CY403025	400 x 300 x 250	直、橫 (Straight/Horizontal)
5	CY404018	400 x 400 x 180	直 (Straight)
6	CY404025	400 x 400 x 250	直 (Straight)
7	CY504018	500 x 400 x 180	直、橫 (Straight/Horizontal)
8	CY504025	500 x 400 x 250	直、橫 (Straight/Horizontal)
9	CY505018	500 x 500 x 180	直 (Straight)
10	CY505025	500 x 500 x 250	直 (Straight)
11	CY605018	600 x 500 x 180	直、橫 (Straight/Horizontal)
12	CY605025	600 x 500 x 250	直、橫 (Straight/Horizontal)
13	CY705018	700 x 500 x 180	直、橫 (Straight/Horizontal)
14	CY705025	700 x 500 x 250	直、橫 (Straight/Horizontal)
15	CY806025	800 x 600 x 250	直、橫 (Straight/Horizontal)
16	CY906025	900 x 600 x 250	直、橫 (Straight/Horizontal)
17	CY1008025	1000 x 800 x 250	直 (Straight)
18	CY1108028	1100 x 800 x 280	直 (Straight)
19	CY1208030	1200 x 800 x 300	直 (Straight)
20	CY1209035	1200 x 900 x 350	直 (Straight)

備註 Note :

- 門片R角一體成形，鍍金工藝完美演繹。
The one-piece processing made an integrally formed round corner with high quality of the panel door.
- 歐規設計、符合IEC529測試、防塵防水、高級粉體烤漆。
Approval by IEC529 test, dustproof and waterproof, powder coat painting finished.
- 齊全庫存尺寸，立即交貨。
Many items and dimensions offer for you choice.
- 另提供面板沖孔服務，酌收工資。
We can service regard drill hole but would be increase a little bit cost.

AE系列、PU
Waterproof PU seal of AE Series



掛壁配件
Wall-mounting accessories



歐式一體成型泡綿及門板
German material of cold-foamed PU automatically injected all-in-one for great resilience and air insulation; durable for over 20 years.

通風過濾網組系列

Fan Filter Series



免安裝工具

- 無須螺絲即可固定安裝
- 獨立四角卡扣專利技術

Toolless

- Fixed free of screws
- Patent clip on the corners



安裝兼容性

- 兼容多款風扇開孔
- 可數個併排安裝

Compliant setup

- Openings in common with former series
- Multiple abreast arrangement could be done



材質

- 台灣奇美全新ABS環保原料

Material

- Adoption of the latest Taiwan CHIMEI ABS Eco-friendly material



濾棉更換方便容易

- 操作簡易快捷的鉸鏈專利技術
- 輕鬆安裝過濾棉

Easy to replace filters

- Patent hinge easy to operate
- Easy to replace filter pads



發泡密封 防水防塵

- 採用德國 RAMPF 發泡設備

Sealant

- Adoption of German RAMPF



▲ 全系列通風過濾網組 All Series of Fan Filters

PFC系列-通風過濾網組

PFC Series of Fan Filter

IP54

ABS



密封膠圈

- 採用德國進口創浦公司的發泡設備和原材料
- 密封性超強, IP等級可達到IP54

Sealing Rubber Gasket

- Adoption of dispensing equipment and material of German TRUMPF
- High sealability up to IP54



材料

- 台灣奇美全新環保ABS原料

Material

- Adoption of ECO-friendly CHIMEI ABS material in Taiwan



配件

- 風機安裝孔內銅螺母
- 可配304不鏽鋼全密封板



Accessory

- Copper nut within mounting hole of fans
- Optional 304 stainless steel sealing panel



安裝

- 上推式裝置, 輕鬆取出過濾棉清洗
- 上下右左固定開卡扣, 一卡即可

Setup

- Push-pull
- Patent clip on the corners



防水倒勾

- 倒齒設計能有效防水、防沙, 還可防止大塊碎片物體滲入

Waterproof Runcinate Shutters

- Runcinate Shutters keep water, dust, and other chips from seeping in



01 主體材料

- 台灣奇美全新ABS環保原料
- Material**
- Adoption of Eco-friendly CHIMEI ABS material in Taiwan

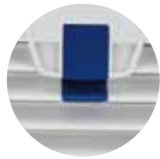

02 拉扣

- 按鈕式拉扣, 只需輕輕一拉, 就能輕鬆取出過濾棉清洗
- 專利設計, 方便、簡易、快速、實用

Fasteners

- Push-button fasteners make opening, replacing and cleaning filter pads quick and simple.
- Patent design, convenient, easy, quick, and functional.



03 結合裝置專利設計

- 外罩與主體結合裝置
 - 拆裝方便, 堅固耐用
- Patent Design**
- Fasteners connecting outer the outer cover and the main part
 - Convenient to dismount, sturdy and durable



04 排水道口

- 安全實用的排道設計, 可將不慎滲入網內的水流從內部順利排出
 - 安全實用, 創意十足。
- Drainage**
- Draining tunnel letting seeping water drained out
 - Safe, practical, and creative



05 發泡密封、防水防塵

- 採用德國進口創浦公司的發泡設備和原材料
 - 密封性超強, IP等級可達到IP54
- Sealing Rubber Gasket**
- Adoption of dispensing equipment and material of German TRUMPF
 - High sealability up to IP54



06 安裝孔

- 風機安裝孔, 內配銅螺母
 - 安裝孔可配選其中任一種規格安裝
- Mounting Hole**
- Copper nut within mounting hole of fans
 - Optional mounting holes of specs



07 專利設計

- 專利設計加強固定卡位
 - 可穩固安裝0.5-3.0mm厚度的板面
 - 安裝簡易, 快捷輕便又耐用, 一卡即可
- Patent Design**
- Reinforcing fixing
 - Firmly fixed into panels of depth 0.5-3.0mm
 - Simple mounting; quick, convenient, and durable clips



08 加強固定(內壓)

- 提高安裝穩固性, 耐用, 一卡即可
- Reinforcing Fixing(Pressing Inward)**
- Durable clips reinforcing stability

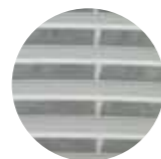

09 防水倒勾

- 倒勾設計能有效的防水、防沙, 還可以防止大塊碎片物體滲入
 - 專利設計
- Patent Waterproof Runcinate Shutters**
- Runcinate Shutters keep water, dust, and other chips from seeping in
 - Patent design

PFD(9803)



可配風機 Optional Fans:
PD80*80, 110*110, 120*120



示意圖 Schematic



額外電壓 ± 10% (rated voltage)		220	V
無阻力風量 (non resistance flow)	IP54	110/125	m ³ /h
	IP55	100/110	
組合風量 (combined air)	IP54	82/93	m ³ /h
	IP55	55/64	
功率 (power)		18	W
電流 (current)		0.4	A
噪音級別 (noise level)	IP54	40	dB (A)
	IP55		
工作負載 (work load)		100	%
溫度範圍 (temperature range)		-15...+55/+5...+131	°C/°F

PFB(9807)

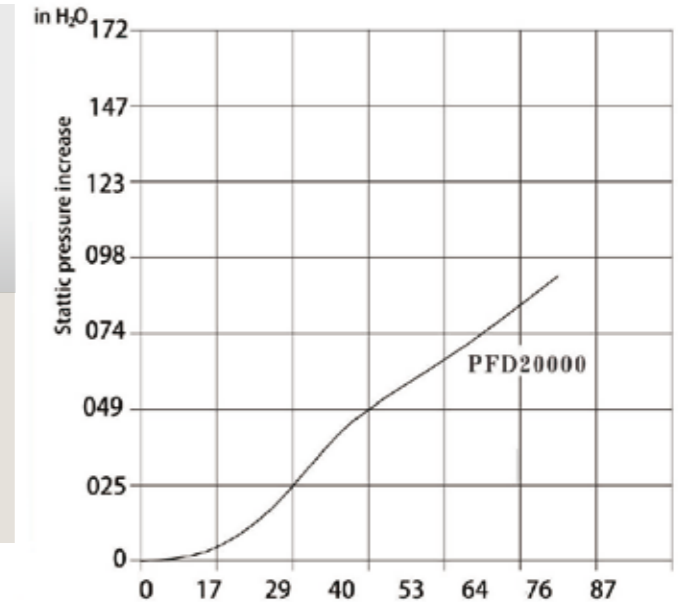
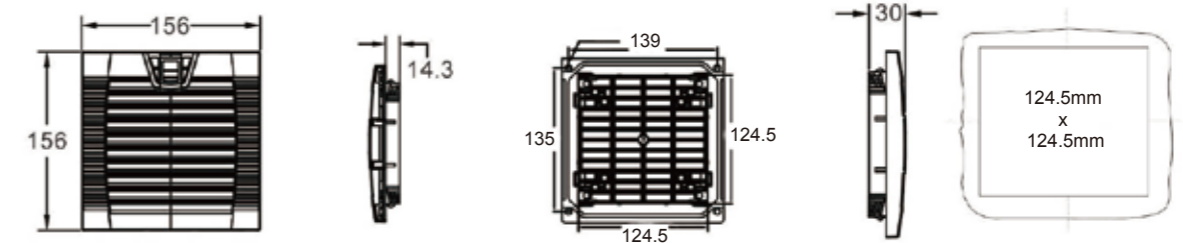
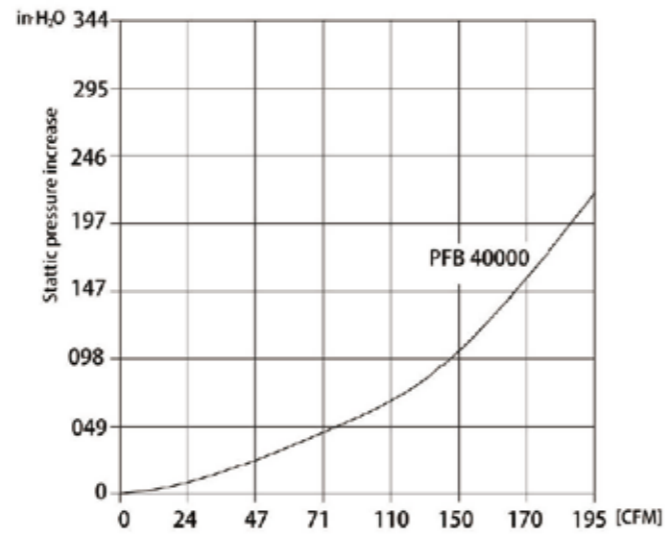

可配風機 Optional Fans:
PD120*120, PD150*170

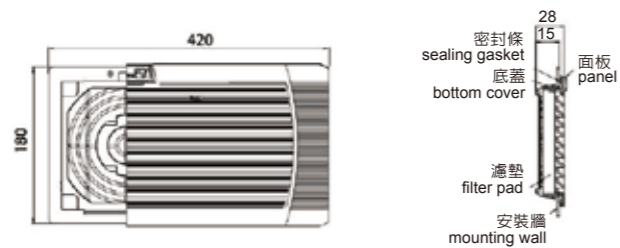

額外電壓 ± 10% (rated voltage)		220	V
無阻力風量 (non resistance flow)	IP54	156/171	m ³ /h
	IP55	145/160	
組合風量 (combined air)	IP54	116/127	m ³ /h
	IP55	109/113	
功率 (power)		25	W
電流 (current)		0.5	A
噪音級別 (noise level)	IP54	40	dB (A)
	IP55	40	
工作負載 (work load)		100	%
溫度範圍 (temperature range)		-15...+55/+5...+131	°C / °F

數控邊角成型機

CNC CORNER FORMING MACHINE

產品特色 Features of Production

- ★數控邊角成型機，使用先進的PLC編程控制器，能夠與其他設備的PLC編程控制器形成數據連結。
- ★數控邊角成型機與折彎機器人的配套使用，代替人工將放好的各種板材自動抓取，進行折彎以及精確的邊角成型，最後分類碼頭，減輕操作人員的勞動強度。
- ★離線編程，事先在電腦上編輯好需要加工板材的控制程序，通過遠端數據傳輸將預先編好的程序傳入機器，大幅提升操作的效率和方便性。
- ★CNC corner forming machine is equipped with advanced Programmable Logic Controller, able to connect with PLC of other equipments.
- ★Cooperation of CNC corner forming machine with Bending robot could reduce labor intensity by automatically grabbing, bending, and precisely forming corners of placed sheet metal.
- ★Programming offline control procedure in advance and then transferring it into the machine via remote data transmission could greatly raise efficiency and conveniency for operation.

鈹金設備行業權威專家
為您的鈹金工廠提供專業技術方案
Experts on profession of sheet metal equipment
provide professional skilled method for your sheet metal industry.



應用範圍 Applications

- 工業機箱、機櫃、門鈹
Industrial computer chassis, Cabinet, Door sheet
- 高低壓開關櫃、門鈹
High / low voltage switch cabinet, Door sheet
- 高低壓電箱、電櫃、門鈹
High / low voltage electronic cabinet, Electric cabinet, Door sheet
- 家用電器鈹金
Household appliance sheet metal

適用材質 Applicable Material

- SPCC冷軋鈹
SPCC cold rolled sheet metal
- 鋁鈹
Aluminium panel
- 不鏽鋼鈹
Stainless steel panel



1 預折彎
Pre-bending



2 邊角成型
Corner-forming



3 餘邊切除
Cutting redundant edge